

# Plan Review for Food Establishments

## TABLE OF CONTENTS

	<b>PAGE</b>
<b>INTRODUCTION</b> .....	1
<b>DEFINITIONS</b> .....	2
<b>MODEL APPLICATION</b> .....	10
<b>REGULATORY AUTHORITY COMPLIANCE REVIEW LIST</b> .....	26
<b>SECTION 1</b> MENU AND FLOW.....	31
<b>SECTION 2</b> FACILITIES TO MAINTAIN PRODUCT TEMPERATURE..	35
<b>SECTION 3</b> FACILITIES TO PROTECT FOOD.....	42
<b>SECTION 4</b> HYGIENE FACILITIES.....	46
<b>SECTION 5</b> WATER SUPPLY AND SEWAGE DISPOSAL.....	49
<b>SECTION 6</b> EQUIPMENT AND INSTALLATION.....	65
<b>SECTION 7</b> DRY STORAGE.....	71
<b>SECTION 8</b> WAREWASHING FACILITIES.....	74
<b>SECTION 9</b> FINISHES - FLOORS, WALLS, CEILINGS.....	76
<b>SECTION 10</b> PEST CONTROL.....	80
<b>SECTION 11</b> LIGHTING.....	81
<b>SECTION 12</b> VENTILATION.....	82
<b>SECTION 13</b> OTHER .....	84
<b>REFERENCES AND BIBLIOGRAPHY</b> .....	86

# INTRODUCTION

This document is intended to assist regulatory health authorities responsible for the review of food establishment plans. Food establishment plan review is recognized as an important component of a retail food protection program that:

- ensures food establishments are built or renovated according to current rules and regulations;
- enhances food safety and sanitation by promoting efficient layout and flow of food based on the menu and food preparation processes; and
- helps prevent code violations by addressing potential layout and design issues prior to construction.

This document:

- Describes effective processes for reviewing plans for the design and construction of new food establishments, as well as the redesign, remodel or conversion of such establishments. It contains useful references to nationally recognized standards for the proper design, installation and construction of food preparation and display facilities in such establishments.
- Is intended as a training tool for individuals responsible for conducting plan reviews and is used in FDA-sponsored training courses on plan review procedures. This document may also help facility designers, plan developers, and establishment operators better understand the expectations of plan review officials. However, it does not establish regulatory requirements and the recommendations contained herein are not intended to supplant, or otherwise serve as, the rules and regulations applicable to food establishments in a given Federal, State, local or tribal jurisdiction.
- Was developed by the Conference for Food Protection's Plan Review Committee and the FDA. It is intended to be consistent with the recommendations of the FDA as contained in the FDA Food Code. The FDA Food Code contains model requirements for safeguarding public health and ensuring food is unadulterated and honestly presented when offered to the consumer.

# FOOD ESTABLISHMENT PLAN REVIEW

## ***DEFINITIONS***

Portions of this section are written in *italics*. These provisions are not requirements, but are provided to convey relevant information about specific exceptions and alternative means for compliance.

**“Acceptable food equipment”** means food equipment that is deemed to be in conformance with Food Code provisions such as equipment that is certified or classified for sanitation by an American National Standards Institute (ANSI)-accredited certification program. Such equipment is deemed to comply with Parts 4-1 and 4-2 of the Food Code.

Under ANSI document CA-1 ANSI Policy and Criteria for Accreditation of Certification Programs, it has been stipulated that:

“For food equipment programs, standards that establish sanitation requirements shall be specified government standards or standards that have been ratified by a public health approval step. ANSI shall verify that this requirement has been met by communicating with appropriate standards developing organizations and governmental public health bodies.”

The term “certified” is used when an item of food equipment has been evaluated against an organization’s own standard. The term “classified” is used when one organization evaluates an item of food equipment against a standard developed by another organization.

**“Air Break”** means a piping arrangement in which a drain from a fixture, appliance, or device discharges indirectly into another fixture, receptacle or interception at a point below the flood level rim. The connection does not provide an unobstructed vertical distance and is not solidly connected but precludes the possibility of backflow to a potable water source

**“Air Gap”** means the unobstructed vertical distance through the free atmosphere between the lowest opening from any pipe or outlet supplying fixture, or other device, and the flood level rim of the receptacle. The vertical physical separation shall be at least two times the inside diameter of the water inlet pipe above the flood rim level but shall not be less than one inch.

**“Approved”** means acceptable to the regulatory authority based on a determination of conformity with principles, practices, and generally recognized standards that protect

public health.

**“Corrosion-resistant material”** means a material that maintains acceptable surface cleanability characteristics under prolonged influence of the food to be contacted, the normal use of cleaning compounds and sanitizing solutions, and other conditions of the use environment.

**“Easily Disassembled Equipment”** means equipment that is accessible for cleaning and inspection by:

- (1) Disassembling without the use of tools, or
- (2) Disassembling with the use of handheld tools commonly available to maintenance and cleaning personnel such as screwdrivers, pliers, open-end wrenches, and Allen wrenches.

**“Easily Movable”** means:

- (1) Portable; mounted on casters, gliders, or rollers; or provided with a mechanical means to safely tilt a unit of equipment for cleaning; and
- (2) Having no utility connection, a utility connection that disconnects quickly, or a flexible utility connection line of sufficient length to allow the equipment to be moved for cleaning of the equipment and adjacent area.

**“Equipment”**

(1) **"Equipment"** means an article that is used in the operation of a food establishment such as a freezer, grinder, hood, ice maker, meat block, mixer, oven, reach-in refrigerator, scale, sink, slicer, stove, table, temperature measuring device for ambient air, vending machine, or warewashing machine.

(2) **"Equipment"** does not include apparatuses used for handling or storing large quantities of packaged foods that are received from a supplier in a cased or overwrapped lot, such as hand trucks, forklifts, dollies, pallets, racks, and skids.

**“Facility”** See **“Physical facilities”**

**“Food Employee”** means an individual working with unpackaged food, food equipment or utensils, or food-contact surfaces

**“Food Establishment”**

- (1) **Food establishment"** means an operation that:

- (a) stores, prepares, packages, serves, vends, **food directly to the consumer**, or otherwise provides FOOD for human consumption such as a restaurant; satellite or catered feeding location; catering operation if the operation provides FOOD directly to a CONSUMER or to a conveyance used to transport people; market; vending location; conveyance used to transport people; institution; or FOOD bank; and
- (b) relinquishes possession of FOOD to a CONSUMER directly, or indirectly through a delivery service such as home delivery of grocery orders or restaurant takeout orders, or delivery service that is provided by common carriers.

(2) **"Food establishment"** includes:

- (a) An element of the operation such as a transportation vehicle or a central preparation facility that supplies a vending location or satellite feeding location *unless the vending or feeding location is permitted by the REGULATORY AUTHORITY*; and
- (b) An operation that is conducted in a mobile, stationary, temporary, or permanent facility or location; where consumption is on or off the PREMISES; and regardless of whether there is a charge for the FOOD.

(3) **"Food establishment"** does not include:

- (a) *An establishment that offers only prePACKAGED FOODS that are not POTENTIALLY HAZARDOUS (TIME/TEMPERATURE CONTROL FOR SAFETY) FOODS;*
- (b) *A produce stand that only offers whole, uncut fresh fruits and vegetables;*
- (c) *A FOOD PROCESSING PLANT including those that are located on the PREMISES of a FOOD ESTABLISHMENT;*
- (d) *A kitchen in a private home if only FOOD that is not POTENTIALLY HAZARDOUS (TIME/TEMPERATURE CONTROL FOR SAFETY) FOOD, is prepared for sale or service at a function such as a religious or charitable organization's bake sale if allowed by LAW and if the CONSUMER is informed by a clearly visible placard at the sales or service location that the FOOD is prepared in a kitchen that is not subject to regulation and inspection by the REGULATORY AUTHORITY;*
- (e) *An area where FOOD that is prepared as specified in Subparagraph (3)(d) of this definition is sold or offered for human consumption;*

- (f) *A kitchen in a private home, such as a small family day-care provider; or a bed-and-breakfast operation that prepares and offers FOOD to guests if the home is owner occupied, the number of available guest bedrooms does not exceed 6, breakfast is the only meal offered, the number of guests served does not exceed 18, and THE CONSUMER is informed by statements contained in published advertisements, mailed brochures, and placards posted at the registration area that the FOOD is prepared in a kitchen that is not regulated and inspected by the REGULATORY AUTHORITY; or*
- (g) *A private home that receives catered or home-delivered FOOD.*

**“Hazard Analysis Critical Control Point (HACCP)”** means a systematic approach to the identification, evaluation, and control of food safety hazards.

**“HACCP Plan”** means a written document which is based upon the principles of HACCP and which delineates the procedures to be followed.

**“Highly susceptible population”** means persons who are more likely than other people in the general population to experience foodborne disease because they are:

- (1) Immunocompromised; preschool age children, or older adults; and
- (2) Obtaining food at a facility that provides services such as custodial care, health care, or assisted living, such as a child or adult day care center, kidney dialysis center, hospital or nursing home, or nutritional or socialization services such as a senior center.

**“Linens”** means fabric items such as cloth hampers, cloth napkins, table cloths, wiping cloths, and work garments including cloth gloves.

**“Physical facilities”** means the structure and interior surfaces of a food establishment including accessories such as soap and towel dispensers and attachments such as light fixtures and heating or air conditioning system vents.

**“Plumbing fixture”** means a receptacle or device that:

- (1) Is permanently or temporarily connected to the water distribution system of the premises and demands a supply of water from the system; or
- (2) Discharges used water, waste materials, or sewage directly or indirectly to the drainage system of the premises.

**“Plumbing system”** means the water supply and distribution pipes; plumbing fixtures and traps; soil, waste, and vent pipes; sanitary and storm sewers and building drains, including their respective connections, devices, and appurtenances within the premises;

and water-treating equipment.

**“Potentially Hazardous Food (Time/Temperature Control for Safety Food)”**

(1) **"Potentially hazardous food (time/temperature control for safety food)"** means a FOOD that requires time/temperature control for safety (TCS) to limit pathogenic microorganism growth or toxin formation.

(2) **"Potentially hazardous food (time/temperature control for safety food)"** includes:

(a) An animal FOOD that is raw or heat-treated; a plant FOOD that is heat-treated or consists of raw seed sprouts, cut melons, cut tomatoes or mixtures of cut tomatoes that are not modified in a way so that they are unable to support pathogenic microorganism growth or toxin formation, or garlic-in-oil mixtures that are not modified in a way so that they are unable to support pathogenic microorganism growth or toxin formation; and

(b) Except as specified in Subparagraph (3)(d) of this definition, a FOOD that because of the interaction of its  $A_w$  and PH values is designated as Product Assessment Required (PA) in Table A or B of this definition:

<b>Table A. Interaction of pH and <math>A_w</math> for control of spores in FOOD heat-treated to destroy vegetative cells and subsequently PACKAGED</b>			
$A_w$ values	<u>pH values</u>		
	4.6 or less	> 4.6 - 5.6	> 5.6
$\leq 0.92$	non-PHF*/non-TCS FOOD**	non-PHF/non-TCS FOOD	non-PHF/non-TCS FOOD
> 0.92 - .95	non-PHF/non-TCS FOOD	non-PHF/non-TCS FOOD	PA***
> 0.95	non-PHF/non-TCS FOOD	PA	PA

\* PHF means POTENTIALLY HAZARDOUS FOOD  
 \*\* TCS FOOD means TIME/TEMPERATURE CONTROL FOR SAFETY FOOD  
 \*\*\* PA means Product Assessment required

<b>Table B. Interaction of pH and A<sub>w</sub> for control of vegetative cells and spores in FOOD not heat-treated or heat-treated but not PACKAGED</b>				
A <sub>w</sub> values	pH values			
	< 4.2	4.2 - 4.6	> 4.6 - 5.0	> 5.0
< 0.88	non-PHF/ non-TCS food**	non-PHF/ non-TCS food	non-PHF/ non-TCS food	non-PHF/ non-TCS food
0.88 – 0.90	non-PHF/ non-TCS food	non-PHF/ non-TCS food	non-PHF/ non-TCS food	PA***
> 0.90 – 0.92	non-PHF/ non-TCS food	non-PHF/ non-TCS food	PA	PA
> 0.92	non-PHF/ non-TCS food	PA	PA	PA
* PHF means POTENTIALLY HAZARDOUS FOOD ** TCS FOOD means TIME/TEMPERATURE CONTROL FOR SAFETY FOOD *** PA means Product Assessment required				

**(3) "Potentially hazardous food (time/temperature control for safety food)" does not include:**

(a) *An air-cooled hard-boiled EGG with shell intact, or an EGG with shell intact that is not hard-boiled, but has been pasteurized to destroy all viable salmonellae;*

(b) *A FOOD in an unopened HERMETICALLY SEALED CONTAINER that is commercially processed to achieve and maintain commercial sterility under conditions of non-refrigerated storage and distribution;*

(c) *A FOOD that because of its pH or A<sub>w</sub> value, or interaction of A<sub>w</sub> and pH values, is designated as a non-PHF/non-TCS FOOD in Table A or B of this definition;*

(d) *A FOOD that is designated as Product Assessment Required (PA) in Table A or B of this definition and has undergone a Product Assessment showing that the growth or toxin formation of pathogenic microorganisms that are reasonably likely to occur in that FOOD is precluded due to:*



*(i) Intrinsic factors including added or natural characteristics of the FOOD such as preservatives, antimicrobials, humectants, acidulants, or nutrients,*

*(ii) Extrinsic factors including environmental or operational factors that affect the FOOD such as packaging, modified atmosphere such as REDUCED OXYGEN PACKAGING, shelf life and use, or temperature range of storage and use, or*

*(iii) A combination of intrinsic and extrinsic factors; or*

*(e) A FOOD that does not support the growth or toxin formation of pathogenic microorganisms in accordance with one of the Subparagraphs (3)(a) - (3)(d) of this definition even though the FOOD may contain a pathogenic microorganism or chemical or physical contaminant at a level sufficient to cause illness or injury.*

**“Premises”** means:

(1) The physical facility, its contents, and the contiguous land or property under the control of the permit holder; or

(2) The physical facility, its contents, and the land or property not described under Subparagraph (1) of this definition if its facilities and contents are under the control of the permit holder and may impact food establishment personnel, facilities, or operations, if a food establishment is only one component of a larger operation such as a health care facility, hotel, motel, school, recreational camp, or prison.

**“Refuse”** means solid waste not carried by water through the sewage system.

**“Regulatory Authority”** means the local, state, or federal enforcement body or authorized representative having jurisdiction over the food establishment.

**“Safe material”** means:

(1) An article manufactured from or composed of materials that may not reasonably be expected to result, directly or indirectly, in their becoming a component or otherwise affecting the characteristics of any food;

(2) An additive that is used as specified in § 409 or 706 of the Federal Food, Drug, and Cosmetic Act; or

(3) Other materials that are not additives and that are used in conformity with

applicable regulations of the Food and Drug Administration.

**“Sealed”** means free of cracks or other openings that allow the entry or passage of moisture.

**“Sewage”** means liquid waste containing animal or vegetable matter in suspension or solution and may include liquids containing chemicals in solution.

**“Smooth”** means:

- (1) A food-contact surface having a surface free of pits and inclusions with a cleanability equal to or exceeding that of (100 grit) number 3 stainless steel;
- (2) A nonfood-contact surface of equipment having a surface equal to that of commercial grade hot-rolled steel free of visible scale; and
- (3) A floor, wall, or ceiling having an even or level surface with no roughness or projections that renders it difficult to clean.

## ***MODEL PLAN REVIEW APPLICATION***

# FOR FOOD ESTABLISHMENTS

The following application is suggested for use to obtain information about the types and quantities of food to be prepared and served and to adequately evaluate the plans and equipment listings provided by the applicant. This application may be modified to meet the needs of the regulatory authority.

Name of Regulatory Authority  
Address  
Telephone/Fax/Website

## FOOD ESTABLISHMENT PLAN REVIEW APPLICATION

\_\_\_\_NEW                      \_\_\_\_REMODEL                      \_\_\_\_CONVERSION

Name of Establishment: \_\_\_\_\_

Type of Food Operation:  
Restaurant\_\_\_\_, Institution\_\_\_\_, Daycare \_\_\_\_  
Retail Food Store\_\_\_\_, Other\_\_\_\_\_.

Establishment  
Address: \_\_\_\_\_

Phone (if available): \_\_\_\_\_

Name of Owner: \_\_\_\_\_

Owner's Mailing Address: \_\_\_\_\_

Owner's  
Telephone: \_\_\_\_\_

Owner's  
Email Address: \_\_\_\_\_

Applicant's Name: \_\_\_\_\_

Title (owner, manager, architect, etc.): \_\_\_\_\_

Applicant's Mailing Address: \_\_\_\_\_

Applicant's Telephone: \_\_\_\_\_

Applicant  
Email Address: \_\_\_\_\_

Hours of Operation: Sun \_\_\_\_\_ Thurs \_\_\_\_\_  
Mon \_\_\_\_\_ Fri \_\_\_\_\_  
Tues \_\_\_\_\_ Sat \_\_\_\_\_  
Wed \_\_\_\_\_

Number of Indoor Dining Seats: \_\_\_\_\_  
Number of Outdoor Dining Seats: \_\_\_\_\_  
Number of Staff: \_\_\_\_\_  
(Maximum per shift)

Total Square Feet of Facility: \_\_\_\_\_

Maximum Meals to be Served: Breakfast \_\_\_\_\_  
(approximate number) Lunch \_\_\_\_\_  
Dinner \_\_\_\_\_

Projected Date for Start of Project: \_\_\_\_\_

Projected Date for Completion of Project: \_\_\_\_\_

Type of Service: Sit Down Meals \_\_\_\_\_  
(check all that apply) Take Out \_\_\_\_\_  
Caterer \_\_\_\_\_  
Single Use Utensils \_\_\_\_\_  
Multi-Use Utensils \_\_\_\_\_  
Other \_\_\_\_\_

Enclose the following documents:

\_\_\_\_\_ Proposed Menu or complete list of food and beverages to be offered (including seasonal, off-site and banquet menus)

\_\_\_\_\_ Plan of food establishment drawn to scale showing location of equipment, plumbing, electrical and mechanical services

\_\_\_\_\_ Equipment schedule including location, plumbing, drain and electrical connections

\_\_\_\_\_ Manufacturer specification sheets for each piece of equipment to be used in the establishment

\_\_\_\_\_ Site plan showing location of food establishment location of building on site including alleys, streets; and location of any outside equipment or facilities (dumpsters, well, septic system - if applicable)

## **CONTENTS AND FORMAT OF PLANS AND SPECIFICATIONS.**

Plans at minimum of 11 x 14 inches in size drawn to scale.

Proposed menu, seating capacity, and projected daily meal volume for the food establishment.

Location of all food equipment. Each piece of equipment must be clearly labeled, marked, or identified. Food equipment schedule which includes the make and model numbers and listing of equipment that is certified or classified for sanitation by an ANSI accredited certification program (when applicable) must be submitted. Elevation drawings may be requested by the Regulatory Authority.

Provisions for adequate rapid cooling, including ice baths and refrigeration, and for hot and cold-holding PHF (TCS).

Handwashing sinks

Warewashing sinks

Food preparation sinks

Auxiliary areas such as storage rooms, garbage rooms, toilets, basements and/or cellars used for storage or food preparation.

Entrances, exits, loading/unloading areas and delivery docks.

Complete finish schedules for each room including floors, walls, ceilings and covered juncture bases.

Plumbing schedule including location of floor drains, floor sinks, water supply lines, overhead waste-water lines, hot water generating equipment with capacity and recovery rate, backflow prevention, and wastewater line connections.

Location of lighting fixtures.

Source of water and method of sewage disposal.

A color coded flow chart may be requested by the Regulatory Authority demonstrating flow patterns for:

- food (receiving, storage, preparation, service);
- dishes (clean, soiled, cleaning, storage);
- trash and garbage (service area, holding, storage, disposal)

Ventilation schedule if requested by the Regulatory Authority

Service sink or curbed cleaning facility with facilities for hanging wet mops or similar wet cleaning tools and for the disposal of mop water and similar liquid waste.

Storage location of poisonous or toxic materials.

Areas for storage of employee personal care items.

Location of refuse, recyclable, and/or returnable containers.

**FOOD SUPPLY**

1. How often will frozen foods be delivered? \_\_\_\_\_
2. How often will refrigerated foods be delivered? \_\_\_\_\_
3. How often will dry goods be delivered? \_\_\_\_\_
4. Provide information on the amount of space (in cubic feet) allocated for:  
Dry storage \_\_\_\_\_,  
Refrigerated Storage \_\_\_\_\_, and  
Frozen storage \_\_\_\_\_.
5. Identify the location and containers that will be used to store bulk food products (rice, flour, sugar, etc.)?  
\_\_\_\_\_

**FOOD PREPARATION**

**FOOD PREPARATION PROCEDURES**

Explain the following with as much detail as possible. Provide descriptions of the specific areas on the plan where food is prepared.

Explain the **handling/preparation procedures** for the following categories of food. Describe the processes from receiving to service including:

- How the food will arrive (frozen, fresh, packaged, etc.)
- Where the food will be stored
- Where (prep table, sink, counter, etc.) the food will be washed, cut, marinated, breaded, cooked, etc.
- When (time of day and frequency/day) food will be handled/prepared

READY-TO-EAT FOOD (e.g., salads, cold sandwiches, raw molluscan shellfish)

---

---

---

---

---

---

---

---

---

---

**PRODUCE**

---

---

---

---

---

---

---

---

---

---

POULTRY

---

---

---

---

---

---

---

---

---

---

MEAT

---

---

---

---

---

---

---

---

---

---

SEAFOOD

---

---

---

---

---

---

---

---

---

---

**THAWING FROZEN PHF (TCS) Food:**

Thawing Method(s) (check all that apply and indicate where thawing will take place):



\_\_\_ Under Refrigeration: \_\_\_\_\_

\_\_\_ Running Water less than 70°F(21°C): \_\_\_\_\_

\_\_\_ Microwave (as part of cooking process): \_\_\_\_\_

\_\_\_ Cooked from frozen state: \_\_\_\_\_

\_\_\_ Other (describe): \_\_\_\_\_

List all foods that will be cooked and served \_\_\_\_\_

\_\_\_\_\_  
\_\_\_\_\_

List all foods that will be hot held prior to service: \_\_\_\_\_

\_\_\_\_\_  
\_\_\_\_\_

List all foods that will be cooked and cooled. \_\_\_\_\_

\_\_\_\_\_  
\_\_\_\_\_

List all foods that will be cooked, cooled and reheated

\_\_\_\_\_  
\_\_\_\_\_

Provide a HACCP plan for specialized processing methods of foods such as Reduced Oxygen Packaging (vacuum packaging, cook-chill, etc.), use of additives to render a food non-PHF (TCS) food, curing and smoking for preservation, and molluscan shellfish tanks.

**HOT/COLD HOLDING:**

1. How will hot PHF(TCS) food be maintained at 135°F (57°C) or above during holding for service? Indicate type, number and location of hot holding units.

\_\_\_\_\_  
\_\_\_\_\_  
\_\_\_\_\_

2. How will cold PHF(TCS) food be maintained at 41°F (5°C) or below during holding for service? Indicate type, number and location of cold holding units.

\_\_\_\_\_  
\_\_\_\_\_

**COOLING:**

Indicate by checking the appropriate boxes how PHF(TCS) food will be cooled to 41°F (5°F) within 6 hours (135°F to 70°F in 2 hours).

--	--	--	--	--	--	--	--

COOLING METHOD	*THICK MEATS	*THIN MEATS	HOT FOODS	COLD FOODS	OTHER	LOCATION
Shallow Pans in Refrigerator						
Ice Baths						
Reduce Volume or Size and place in Refrigerator						
Mechanical Rapid Chill Unit						
Stirring with Frozen Stir Sticks						
Other (describe)						

\* Thick meats = more than an inch; Thin meats = one inch or less.

**REHEATING:**

How and where will PHF(TCS) foods that are cooked, cooled, and reheated for hot holding be reheated so that all parts of the food reach a temperature of at least 165°F for 15 seconds within 2 hours. Indicate type and number of units used for reheating foods.

---



---



---



---

**FINISH SCHEDULE**

Indicate which materials (quarry tile, stainless steel, Fiberglass Reinforced Panels (FRP), ceramic tile, 4" plastic covered molding, etc.) will be used in the following areas.

AREA	FLOOR	FLOOR/WALL	WALLS	CEILING
------	-------	------------	-------	---------

		JUNCTURE		
<b>Kitchen</b>				
<b>Bar</b>				
<b>Food Storage</b>				
<b>Other Storage</b>				
<b>Toilet Rooms</b>				
<b>Dressing Rooms</b>				
<b>Garbage &amp; Refuse Storage</b>				
<b>Mop Service Sink</b>				
<b>Warewashing Area</b>				
<b>Walk-in Refrigerators and Freezers</b>				
<b>Other</b>				
<b>Other</b>				

Identify the finishes of cabinets, countertops, and shelving:

---



---



---

**PEST CONTROL**

	<b>YES</b>	<b>NO</b>	<b>NA</b>
1. Will all outside doors be self-closing and rodent proof ?	( )	( )	( )
2. Will screens be provided on all entrances left open to the outside?	( )	( )	( )
3. Will all openable windows have a minimum #16 mesh screening?	( )	( )	( )
4. Will electrical insect control devices be used?	( )	( )	
5. Will air curtains be used? If yes, where? _____	( )	( )	
6. Identify how all pipes & electrical conduit chases be sealed. _____ _____			
7. How will the area around building be kept clear of unnecessary brush, litter, boxes and other harborage? _____ _____			

**REFUSE, RECYCLABLES, AND RETURNABLES**

1. Will refuse/garbage be stored inside? If so, where?  
\_\_\_\_\_
2. Identify how and where garbage cans and floor mats will be cleaned.  
\_\_\_\_\_  
\_\_\_\_\_
3. Will a dumpster or a compactor be used? \_\_\_\_\_  
Number \_\_\_\_\_ Size \_\_\_\_\_  
Frequency of pickup \_\_\_\_\_
4. Will garbage cans be stored outside? \_\_\_\_\_
5. Describe surface and location where dumpster/compactor/garbage cans will be stored outside the establishment  
\_\_\_\_\_  
\_\_\_\_\_
6. Identify location of grease storage containers  
\_\_\_\_\_

---

---

7. Will there be an area to store recyclables? \_\_\_\_\_

If yes, describe \_\_\_\_\_  
\_\_\_\_\_

8. Identify the area to store returnable damaged goods.

\_\_\_\_\_  
\_\_\_\_\_

**WATER SUPPLY**

1. Is the water supply public ( ) or non-public/private ( ) ?

2. If private, has source been approved? YES ( ) NO ( )  
Attach copy of written approval and/or permit.

3. Is ice made on premises ( ) or purchased commercially ( ) ?  
Will there be an ice bagging operation? YES ( ) NO ( )

4. What is the capacity and location of the water heater? Provide specifications for the water heater. \_\_\_\_\_

**SEWAGE DISPOSAL**

1. Is the sewage system public ( ) or non-public/private ( ) ?

2. If private, has sewage system been approved? YES ( ) NO ( )  
Attach copy of written approval and/or permit.

3. Will grease traps/interceptors be provided? YES ( ) NO ( )  
If so, where? \_\_\_\_\_

**BACKFLOW PREVENTION**

	<b>AIR GAP</b>	<b>AIR BREAK</b>	<b>VACUUM BREAKER</b>	<b><u>OTHER</u></b>
<b>1. Dishwasher</b>				
<b>2. Garbage Grinder</b>				
<b>3. Ice machines</b>				
<b>4. Ice storage bin</b>				
<b>5. Sinks</b> a. Mop b. 3 Compartment c. 2 Compartment d. 1 Compartment				
<b>6. Steam tables</b>				
<b>7. Dipper wells</b>				
<b>8. Refrigeration condensate/ drain lines</b>				
<b>9. Hose bibb connection</b>				
<b>10. Potato peeler</b>				
<b>11. Beverage Dispenser w/carbonator</b>				
<b>12. Other</b>				
<b>13. Other</b>				
<b>14. Other</b>				

Identify the locations of all floor drains, if provided.

---



---

**DISHWASHING FACILITIES**

**Manual Dishwashing**

1. Identify the length, width, and depth of the compartments of the 3-compartment sink:

---

2. Will the largest pot and pan fit into each compartment of the 3-compartment sink?

YES ( ) NO ( )

If no, what will be the procedure for manual cleaning and sanitizing of items that will not fit into the sink compartments?

---

---

3. Describe size, location and type (drainboards, wall-mounted or overhead shelves, stationary or portable racks) of air drying space:

---

---

---

---

Square feet of air drying space: \_\_\_\_\_ ft<sup>2</sup>

4. What type of sanitizer will be used?

Chemical ( )  
Hot water ( )

**Mechanical Dishwashing**

5. Identify the make and model of the mechanical dishwasher: \_\_\_\_\_

6. What type of sanitizer will be used?

Chemical ( )  
Hot water ( )

7. Will ventilation be provided?

YES ( ) NO ( )

**HANDWASHING/TOILET FACILITIES**

Identify the locations of the handwashing sinks and toilet facilities:

---

---

**DRESSING ROOMS**

1. Will dressing rooms be provided? YES ( ) NO ( )
2. Describe storage facilities for employees' personal belongings (i.e., purse, coats, boots, umbrellas, etc.) \_\_\_\_\_  
\_\_\_\_\_

**OTHER**

1. Identify the location for the storage of poisonous or toxic materials.  
\_\_\_\_\_  
\_\_\_\_\_

2. Where will cleaning and sanitizing solutions be stored at workstations? How will these item be separated from food and food contact surfaces?  
\_\_\_\_\_  
\_\_\_\_\_  
\_\_\_\_\_

3. Will linens be laundered on site?  
If yes, what will be laundered and where? \_\_\_\_\_  
\_\_\_\_\_  
If no, how and where will linens be cleaned? \_\_\_\_\_

4. Identify location of clean and dirty linen storage:  
\_\_\_\_\_

5. How often will linens be delivered and picked up?  
\_\_\_\_\_

6. Indicate all areas where exhaust hoods will be installed:  
\_\_\_\_\_  
\_\_\_\_\_  
\_\_\_\_\_

7. Identify location of the facilities for cleaning of mops and other equipment:  
\_\_\_\_\_  
\_\_\_\_\_



\*\*\*\*\*

**STATEMENT:** I hereby certify that the above information is correct, and I fully understand that any deviation from the above without prior permission from this Health Regulatory Authority may nullify final approval.

Signature \_\_\_\_\_

owner or responsible representative

Printed Name: \_\_\_\_\_

Date: \_\_\_\_\_

\*\*\*\*\*

**Approval of these plans and specifications by this Regulatory Authority does not indicate compliance with any other code, law or regulation that may be required-- federal, state, or local. It further does not constitute endorsement or acceptance of the completed establishment (structure or equipment). A preopening inspection of the establishment with equipment in place and operational will be necessary to determine if it complies with the local and state laws governing food service establishments.**

# REGULATORY AUTHORITY COMPLIANCE REVIEW LIST AND APPROVAL/DISAPPROVAL FORM

## REGULATORY AUTHORITY COMPLIANCE REVIEW LIST

	<u>SAT.</u>	<u>UNSAT.</u>	<u>N/A</u>	<u>INSUFF. INFORM.</u>
<b>1. Food Preparation Review</b>				
Raw food prep table(s)	( )	( )	( )	( )
Raw food prep sink(s)	( )	( )	( )	( )
Adequate refrigeration	( )	( )	( )	( )
Adequate cold holding facilities	( )	( )	( )	( )
Adequate hot holding facilities	( )	( )	( )	( )
Adequate hot food preparation equip.	( )	( )	( )	( )
Vacuum packaging (HACCP plan)	( )	( )	( )	( )
<b>2. Utensil &amp; Equipment</b>				
Clean Storage	( )	( )	( )	( )
Soiled Storage	( )	( )	( )	( )
Counter mounted equip.	( )	( )	( )	( )
Floor mounted equip.	( )	( )	( )	( )
Vacuum packaging equip.	( )	( )	( )	( )
Bulk food	( )	( )	( )	( )
Self service				
Salad Bar	( )	( )	( )	( )
Hot/Cold Buffet	( )	( )	( )	( )
				<b><u>INSUFF.</u></b>

	<u>SAT.</u>	<u>UNSAT.</u>	<u>N/A</u>	<u>INFORM.</u>
<b>3. Kitchen Equipment</b>				
Space between units or wall closed; moveable, or adequate space for easy cleaning	( )	( )	( )	( )
Work space & aisles sufficient	( )	( )	( )	( )
Storage 6" off floor	( )	( )	( )	( )
Countertops & cutting boards of suitable material	( )	( )	( )	( )
Self serve food area adequately protected	( )	( )	( )	( )
Approved thermometer for each refrigerator & freezer, and for taking food temperatures	( )	( )	( )	( )
<b>4. Finish Schedule</b>				
Kitchen	( )	( )	( )	( )
Bar	( )	( )	( )	( )
Food Storage	( )	( )	( )	( )
Other Storage	( )	( )	( )	( )
Toilet Rooms	( )	( )	( )	( )
Dressing Rooms	( )	( )	( )	( )
Garbage & Refuse Storage	( )	( )	( )	( )
Mop Service Area	( )	( )	( )	( )
Warewashing Area	( )	( )	( )	( )
Walk-in refrigerator & freezers	( )	( )	( )	( )
Other	( )	( )	( )	( )
<b>5. Plumbing</b>				
Cross Connections Water lines	( )	( )	( )	( )
Cross Connections Drains	( )	( )	( )	( )
Water Supply	( )	( )	( )	( )
Sewage Disposal	( )	( )	( )	( )
Hand Sinks	( )	( )	( )	( )
Dishwashing & Pot Sinks	( )	( )	( )	( )
Grease Traps	( )	( )	( )	( )

	<u>SAT.</u>	<u>UNSAT.</u>	<u>N/A</u>	<u>INSUFF INFORM.</u>
Service/Janitorial Sinks	( )	( )	( )	( )
Hot Water	( )	( )	( )	( )
<b>6. Physical Facilities</b>				
Dressing Rooms	( )	( )	( )	( )
Separate Toxic Storage	( )	( )	( )	( )
Laundry Facilities	( )	( )	( )	( )
Linen Storage	( )	( )	( )	( )
Lighting	( )	( )	( )	( )
Food Storage	( )	( )	( )	( )
Dry goods storage	( )	( )	( )	( )
<b>7. Refuse &amp; Pest Control</b>				
Garbage & Refuse Storage	( )	( )	( )	( )
Insect & Rodent Control Measures	( )	( )	( )	( )
<b>8. Ventilation</b>				
Exhaust Hoods	( )	( )	( )	( )
Ventilation	( )	( )	( )	( )
<b>9. Restrooms</b>				
Location	( )	( )	( )	( )
Number_____	( )	( )	( )	( )
Soap Dispensers	( )	( )	( )	( )
Hand Drying	( )	( )	( )	( )
Sinks	( )	( )	( )	( )
Toilets	( )	( )	( )	( )
Urinals	( )	( )	( )	( )
Hot and Cold Water Provided	( )	( )	( )	( )
Waste Receptacles	( )	( )	( )	( )

**Comments:** (explain why any item was noted "Unsatisfactory")

---

---

---

---

---

---

---

---

---

---

---

---

---

---

---

---

---

---

---

---

---

---

---

---

**Reviewer Signature**

\_\_\_\_\_ **Date**

**Reviewer Title**

**APPROVAL:** \_\_\_\_\_

**DATE:** \_\_\_\_\_

**DISAPPROVAL:** \_\_\_\_\_

**DATE:** \_\_\_\_\_

**REASON FOR DISAPPROVAL:**

---

---

---

---

---

---

---

---

---

---

---

---

---

---

---

---

---

---

---

---

---

---

---

---

## **SECTION 1 – MENU AND FLOW**

The menu review and the flow of food through the facility are integral parts of the plan review process. The menu or a listing of all of the food and beverage items to be offered at the food establishment must be submitted by the applicant to the regulatory authority with the submission of all other Plan Review application documents.

As with the inspection process, the plan review process should focus on the food and its flow through receipt, storage, preparation and service. The source and quantity of food to be served should be reviewed along with the preparation and post-preparation operations. It is imperative to have a knowledge of this information so that a proper assessment of the physical facilities can be made.

Layout, flow and menu (including food preparation processes) should be major considerations to help facilitate an operator's Active Managerial Control (AMC) of the risk factors for foodborne illness. Strategic layout and placing of facilities and equipment will separate different food preparation processes, a major step towards preventing contamination of food that may result from poor personal hygiene, contaminated equipment, and improper holding temperatures. Adequate and convenient storage will also enhance operations. The menu and methods of food preparation are the key elements in the layout and flow of the establishment.

Food preparation processes should be evaluated to determine the types and volumes of foods to be prepared. Special attention should be given to the review of complex food processes which involve:

- Multiple ingredients being assembled or mixed
- Potentially hazardous foods (time/temperature control for safety foods)
- Foods which will be prepared or held for several hours prior to service
- Foods requiring cooling and reheating
- Multiple step processing (passing through the critical temperature zone, 135°F - 41°F more than once)

The process approach can be described as dividing the many flows in an establishment into broad categories, analyzing the risks, and placing manager controls on each grouping. These groupings will also impact the facility design; food flow; and the numbers, types, function and placement of equipment.

The food that flows through retail food establishment operations can be placed into the 3 following processes:

- **FOOD PROCESSES WITH NO COOK STEP**
  - **Receive – Store - Prepare – Hold – Serve**  
(Other processes may occur, but there is **NO cooking step**)
  - Examples: Salads, deli meats, cheeses, sashimi, raw oysters
  
- **FOOD PREPARATION FOR SAME DAY SERVICE**
  - **Receive – Store - Prepare - Cook – Hold – Serve**  
(Other processes may occur, including thawing)
  - Examples: Hamburgers, fried chicken, hot dogs
  
- **COMPLEX PROCESSES**
  - **Receive – Store - Prepare – Cook – Cool – Reheat – Hot Hold – Serve**  
(Other processes may occur, but the key is repeated trips through the temperature danger zone)
  - Examples: Refried beans, leftovers

The system is very useful since the critical control points for each process remain the same regardless of the individual menu ingredients.

The menu for a food establishment dictates the space and equipment requirements for the safe preparation and service of various food items. The menu will determine if the proposed receiving and delivery areas, storage area, preparation and handling areas, and thawing, cooking and reheating areas are available and adequate to handle the types and volumes of foods being prepared and served.

When reviewing the menu, it is important to evaluate the flow patterns for the preparation of the food to be sure that the lay-out of the facility provides an adequate separation of raw ingredients from ready-to-eat foods, and that the traffic patterns are not crossing paths with waste items and other sources of contamination. Cross contamination can be minimized when the flow of food is considered during plan review.

With a proper understanding of the menu and flow, the plans for food establishments can be reviewed to help assure that the food items being considered can be protected during all aspects of the food operation.

Equipment and facilities can be evaluated by following the food flow processes.

Food Flow Process with NO COOK STEP	Receive	Store	Prepare	Hold	Serve
Equipment & Facilities that may be used	Thermometers	Dry Storage Refrigerated Storage Frozen Storage Thermometers	Preparation Tables Cutting Boards Utensils Handwash Sinks Preparation Sinks Refrigerators	Refrigerators Ice Cold Holding Facilities Thermometers Handwashing Sinks	Cold Holding Facilities at the Service Area Thermometers Handwashing Sinks

Food Preparation for SAME DAY SERVICE	Receive	Store	Prepare	Cook	Hold	Serve
Equipment & Facilities that may be used	Thermometers	Dry Storage  Refrigerated Storage  Frozen Storage  Thermometers	Preparation Tables  Cutting Boards  Utensils Handwash Sinks  Preparation Sinks  Refrigerators	Cooking Equipment -Fryers -Ovens -Broilers -Grills -Cook Tops -Griddles -Other Thermometers Handwashing Sinks	Refrigerators Ice Cold Holding Facilities Hot Holding Facilities Food Warmers Preparation Worktops/Tables Thermometers Handwashing Sinks	Cold Holding Facilities at the Service Area  Thermometers Handwashing Sinks



Complex Processes	Receive	Store	Prepare	Cook	Cool	Reheat	Hold	Serve
Equipment & Facilities that may be used	Thermometers	Dry Storage Refrigerated Storage Frozen Storage Thermometers	Preparation Tables Cutting Boards Utensils Handwash Sinks Preparation Sinks Refrigerators	Cooking Equipment -Fryers -Ovens -Broilers -Grills -Cook Tops -Griddles -Other Thermometers Hand washing Sinks	Preparation Sinks Ice Baths Blast Chillers Shallow Pans Refrigerators Chill Sticks Thermometers Hand washing Sinks Preparation Tables Other	Fryers Ovens Grills Burners Griddles Other Hand washing Sinks	Refrigerators Ice Cold Holding Facilities Hot Holding Facilities Food Warmers Preparation Worktops/Tables Thermometers Handwashing Sinks	Cold Holding Facilities at the Service Area Thermometers Hand washing Sinks

## **SECTION 2- FACILITIES TO MAINTAIN PRODUCT TEMPERATURE**

Hot-holding and cold-holding facilities must be designed, constructed and installed to comply with Chapter 4 of the FDA Food Code. Food equipment that is certified or classified for sanitation by an ANSI accredited program is deemed to comply with Parts 4-1 and 4-2 of the FDA Food Code.

### **REFRIGERATION SIZING AND DESIGN**

Plan review must consider the need to provide adequate refrigeration facilities for the proper storage, transportation, display, and service of PHF(TCS) food. Specific refrigeration needs are based on the menu, number of meals, frequency of deliveries, and food to be prepared in advance of service. All refrigerators must be capable of maintaining PHF(TCS) food at 41°F or below.

If PHF(TCS) foods are prepared a day or more in advance of service, a rapid cooling procedure capable of cooling PHF(TCS) foods from 135°F to 41°F within 6 hours (135°F to 70°F within 2 hrs.) must be provided. The capacity of the rapid cooling facilities must be sufficient to accommodate the volume of food required to be cooled to 41°F within 6 hours. The location of the rapid cooling facilities (e.g., sinks for ice baths, freezer storage for ice wands, blast chillers) must be identified. Refrigerators and freezers at work stations for operations requiring preparation and handling of PHF(TCS) foods should be considered. For example, it may be necessary to locate a freezer near the fryer where frozen products will be deep-fried. Refrigeration units, unless designed for such use, should not be located directly adjacent to cooking equipment or other high heat producing equipment which may adversely impact the cooling system's operation.

### **CALCULATING REFRIGERATED STORAGE NEEDS**

To plan refrigeration storage, the following items should be considered: menu, type of food operation, number of meals per day, number of deliveries per week, and adequate ventilation in the areas where the refrigeration systems will be located.

One formula that can be used to establish required walk-in refrigeration storage is:

Total Interior Storage Volume Needed:

$$\frac{\text{Volume per meal}^1 (\text{ft.}^3) \times \text{number of meals between deliveries}}{.40^2}$$

For example, if a food establishment serves 1,000 meals between deliveries, the following refrigerated walk-in storage capacity would be needed:

$$\frac{0.1 \text{ ft.}^3/\text{meal} \times 1000 \text{ meals}}{.40} = 250 \text{ cubic feet}$$

<sup>1</sup>Volume per meal is estimated to be 0.1 cubic feet

<sup>2</sup> Only 40% of any walk-in unit actually provides usable space.

The following charts are based on the volume of the meals, number of meals served and frequency of delivery.  
**Note: To calculate the interior floor area (ft<sup>2</sup>) required for walk-in refrigeration units using the following charts, divide the storage volume by the height of the unit.**

**COLD STORAGE CHART FOR WALK-IN UNITS**  
**0.10 Cu.Ft.. per meal for all cold storage products**

Number of meals served between deliveries	Storage volume of walk-in Cu.Ft.		Number of meals served between deliveries	Storage volume of walk-in Cu.Ft.		Number of meals served between deliveries	Storage volume of walk-in Cu.Ft.
200	50.00		1050	262.50		2050	512.50
250	62.50		1100	275.00		2100	525.00
300	75.00		1150	287.50		2150	537.50
350	87.50		1200	300.00		2200	550.00
400	100.00		1250	312.50		2250	562.50
450	112.50		1300	325.00		2300	575.00
500	125.00		1350	337.50		2350	587.50
550	137.50		1400	350.00		2400	600.00
600	150.00		1450	362.50		2450	612.50
650	162.50		1500	375.00		2500	625.00
700	175.00		1550	387.50		2550	637.50
750	187.50		1600	400.00		2600	650.00
800	200.00		1650	412.50		2650	662.50
850	212.50		1700	425.00		2700	675.00
900	225.00		1750	437.50		2750	687.50
950	237.50		1800	450.00		2800	700.00
1000	250.00		1850	462.50		2850	712.50
			1900	475.00		2900	725.00
			1950	487.50		2950	737.50
			2000	500.00		3000	750.00

One formula that can be used to establish required reach-in refrigeration storage is:

Total Interior Storage Volume Needed:

$$\frac{\text{Volume per meal}^3 (\text{ft.}^3) \times \text{number of meals between deliveries}}{.75^4}$$

For example, if a food establishment serves 1,000 meals between deliveries, the following reach-in refrigerated storage capacity would be needed:

$$\frac{\text{ft.}^3/\text{meal} \times 1000 \text{ meals}}{.75^4} = 133 \text{ cubic feet}$$

0.1

.75

---

<sup>3</sup> Volume per meal is estimated to be 0.1 cubic feet

<sup>4</sup> Only 75% of any reach-in unit actually provides usable space.

**STORAGE CHART FOR REACH-IN UNITS**  
**0.10 Cu.Ft. per meal for all cold storage products**

Number of meals served between deliveries	Storage volume of reach-in Cu. Ft.	Number of meals served between deliveries	Storage volume of reach-in Cu. Ft.	Number of meals served between deliveries	Storage volume of reach-in Cu. Ft.
200	26.67	1050	140.00	2050	273.33
250	33.33	1100	146.67	2100	280.00
300	40.00	1150	153.33	2150	286.67
350	46.67	1200	160.00	2200	293.33
400	53.33	1250	166.67	2250	300.00
450	60.00	1300	173.33	2300	306.67
500	66.67	1350	180.00	2350	313.33
550	73.33	1400	186.67	2400	320.00
600	80.00	1450	193.33	2450	326.67
650	86.67	1500	200.00	2500	333.33
700	93.33	1550	206.67	2550	340.00
750	100.00	1600	213.33	2600	346.67
800	106.67	1650	220.00	2650	353.33
850	113.33	1700	226.67	2700	360.00
900	120.00	1750	233.33	2750	366.67
950	126.67	1800	240.00	2800	373.33
1000	133.33	1850	246.67	2850	380.00
		1900	253.33	2900	386.67
		1950	260.00	2950	393.33
		2000	266.67	3000	400.00

ADDITIONAL REQUIREMENTS AND RECOMMENDATIONS FOR REFRIGERATED  
AND FROZEN STORAGE FACILITIES

- A. All refrigeration units must have numerically scaled indicating thermometers accurate to  $\pm 3^{\circ}\text{F}$ . Temperature sensing devices must be located in the unit to measure air temperature in the warmest part of the refrigerator (usually near a door opening). Refrigerators and freezers shall be capable of maintaining required temperatures.
- B. Air circulation within refrigeration and freezer units should not be obstructed and should allow for an even and consistent flow of cold air throughout the units.
- C. Interior and exterior floor/wall junctures of walk-in refrigerators and freezers must have approved coved junctures.
- D. The use of galvanized metal in refrigerated storage facilities is subject to rust that may lead to cleaning and durability issues.
- E. Gaps and openings around walk-in refrigerator and freezers must be properly sealed to the walls or properly spaced to allow for cleaning behind and around the units. Reach-in refrigerators and freezers that are fixed in place shall be spaced to allow for cleaning along all sides of the unit or sealed to adjoining equipment or walls. Refer to Section 6 of this document.
- F. Refrigeration and freezer units should not be installed with access from the exterior of the building unless food can be protected when transported from the unit into the food establishment.
- G. If the walk-in floors will be water-flushed for cleaning or receive the discharge of liquid waste or excessive melt water, the floors should be sloped to drain. If the structure of the walk-in is integral with the building, properly installed floor drains may be installed inside the unit.
- H. Each walk-in unit shall be equipped with lighting that provides 10 foot candles of light throughout the unit when it is full of product. Lights must be properly shielded or shatter resistant.
- I. Lockable casters are recommended for reach-in refrigerators and freezers.

RAPID CHILL REFRIGERATION UNITS

Construction and installation of rapid chill refrigeration units (i.e., blast chillers) shall be similar to refrigerated and frozen storage facilities. Rapid chill refrigeration units must be capable of cooling cooked PHF(TCS) food from  $135^{\circ}\text{F}$  to  $41^{\circ}\text{F}$  within 6 hours ( $135^{\circ}\text{F}$  to  $70^{\circ}\text{F}$  within 2 hrs.).

## COOKING FACILITIES

- A. The types and location of cooking facilities must be based upon the types and methods of food preparation.
- B. Cooking facilities must be capable of heating PHF(TCS) food to the minimum time/temperature requirements:

beef roasts	130°F (112 min)
cooked fruits and vegetables being hot held	135 °F
solid seafood pieces	145°F (15 sec)
other PHF(TCS) food	145°F (15 sec)
eggs:	
Immediate service	145°F (15 sec)
pooled*	155°F (15 sec)

(\*pasteurized eggs must be served to a highly susceptible population)

pork	145°F (15 sec)
comminuted meats/fish	155°F (15 sec)
poultry	165°F (15 sec)
reheated PHF(TCS) food	165°F (15 sec)
stuffed fish, meat, pork	165 °F (15 sec)

- C. Cooking equipment must be constructed and installed in accordance with Chapter 4 of the FDA Food Code.
- D. Lockable casters with flexible utility lines are recommended to facilitate cleaning. Refer to Section 6 of this document.
- E. If cooking equipment uses water or steam, methods for filling and draining the units must be identified.

## HOT HOLDING AND REHEATING FACILITIES

- A. Hot holding facilities must be capable of maintaining PHF(TCS) food at an internal temperature of 135°F or above during display, service and holding periods.
- B. Reheating equipment must be capable of raising the internal temperature of PHF(TCS) food rapidly (within a maximum of 2 hours) to at least 165°F. Appropriate product thermometers will be required to monitor the food temperature.
- C. Hot holding and reheating facilities must be constructed and installed in accordance with Chapter 4 of the FDA Food Code.
- D. Lockable casters with flexible utility lines are recommended to facilitate cleaning. Refer to Section 6 of this document.
- E. If hot holding units use water or steam, methods for filling and draining the units must be identified.



## **SECTION 3 - FACILITIES TO PROTECT FOOD**

Adequate facilities must be provided to protect food, promote good hygienic practices, and minimize the potential of cross contamination between ready-to-eat food and raw products.

### **GENERAL FOOD PROTECTION**

Food preparation areas for handling, washing and preparing raw meat, fish, and poultry must be identified. Procedures for cleaning and sanitizing food contact surfaces, equipment, and utensils between use must be identified during plan review.

All food being displayed, served, or held must be adequately protected from contamination by the use of: packaging; serving line, storage or salad bar protection devices; display cases; or by other effective means.

Food shields should intercept the direct line between the customer's mouth and the food on display. The average height of a customer's mouth is 4'6" to 5'. This average may have to be adjusted for small children in educational institutions and for other special installations. Figures 3-1 through 3-3 are examples of food shields and how to measure them for protection.

Cleaned equipment and utensils shall be stored in a clean, dry location where they are not exposed to splash, dust, or other contamination. Clean equipment and utensil storage should be identified at utensil-washing areas, plating areas, service areas, salad bars, wait stations and other areas where cleaned items are stored or dispensed.

### **FOOD PREPARATION SINKS**

Separate food preparation sinks for working with raw foods followed by working with ready-to-eat foods should be considered. If separate food preparation sink(s) are not proposed, written procedures for cleaning and sanitizing sinks between uses should be provided during the plan review process.

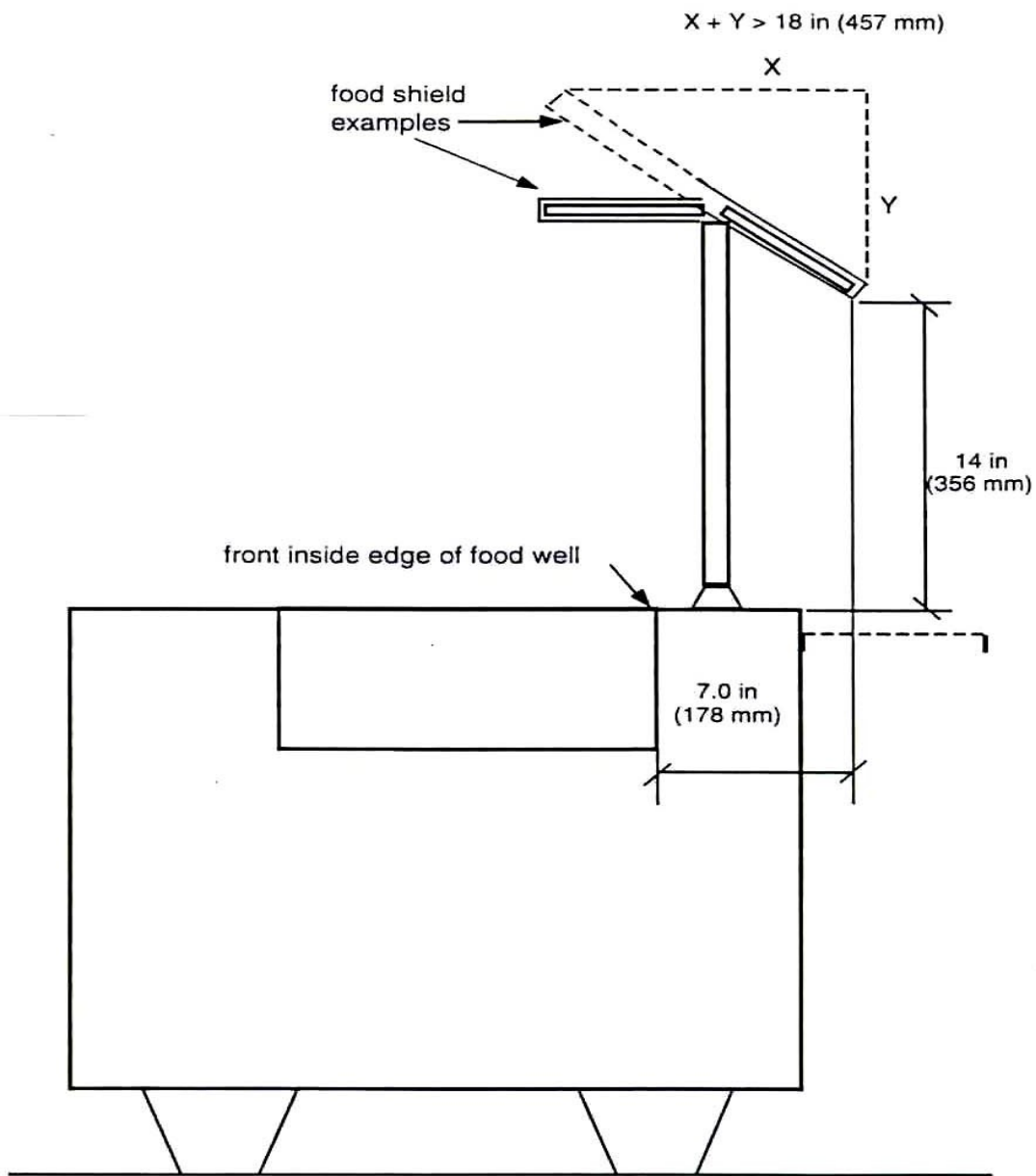

## Buffet Food Shields

Measured from Counter Top

Figure 3-1

### Double Buffet Service

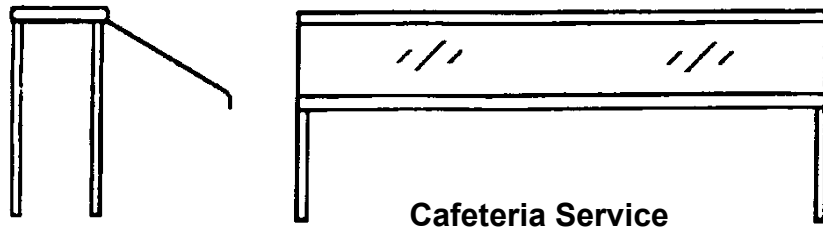
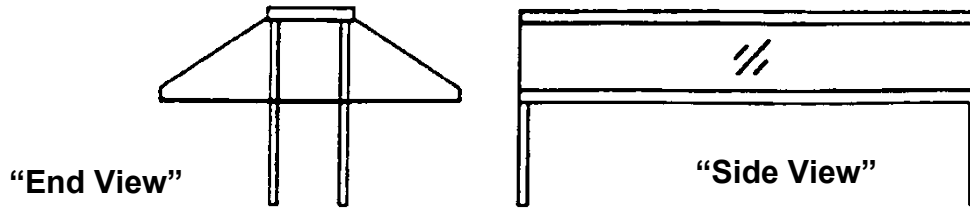

Cafeteria Service

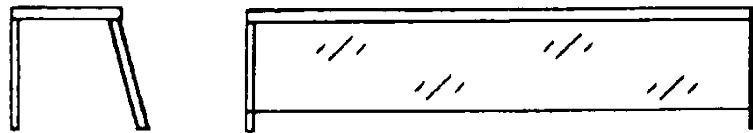

Single Buffet Service

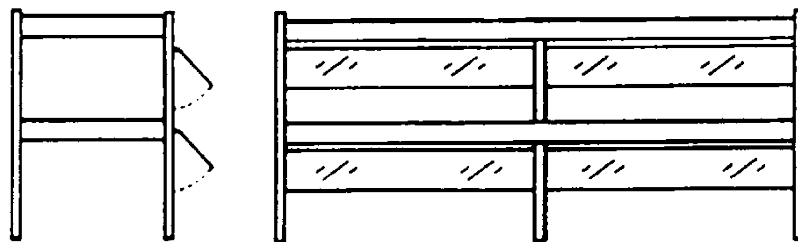

Double Tier Cafeteria Service

## Buffet Food Shields

Figure 3-2

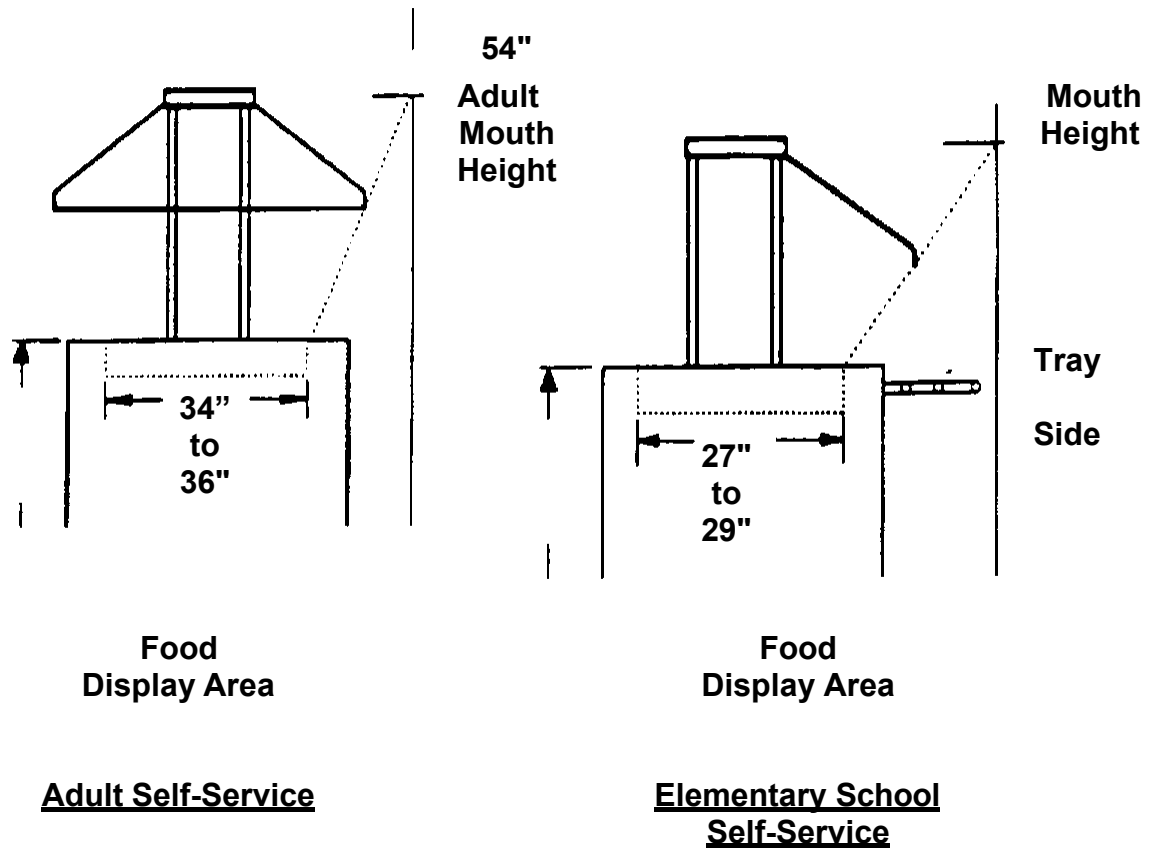

## Buffet Food Shields

Measured from Floor

Figure 3-3

## **SECTION 4 – HYGIENE FACILITIES**

### **HANDWASHING**

Handwashing is a critical factor to prevent contamination of foods. Proper handwashing reduces the amount of pathogens that can be transmitted via cross contamination from raw foods to ready-to-eat foods. Many employees fail to wash their hands as often as necessary due to the lack of conveniently located handwashing sinks. It is important that handwashing be done only at properly equipped handwashing sinks to help ensure that employees effectively clean their hands and minimize contamination of food and food contact surfaces.

A handwashing sink, hand drying device or disposable towels, hand cleanser and waste receptacle shall be located for convenient use by employees who work in food preparation, food dispensing, and warewashing areas. Nothing must block the approach to a handwashing sink. Handwashing sinks must also be located in or immediately adjacent to toilet rooms. Handwashing sinks shall be of sufficient number and conveniently located for use by all employees in food preparation, food dispensing, and washing areas. Handwashing sinks shall be easily accessible and may not be used for purposes other than handwashing. Sinks used for food preparation or for washing equipment or utensils shall not be used for handwashing.

Each handwashing sink shall be provided with hot and cold water tempered by means of a mixing valve or a combination faucet to provide water at a temperature of at least 100°F. If used, self-closing, slow-closing or metering faucets shall be designed to provide a flow of water for at least 15 seconds without the need to reactivate the faucet.

Splash from use of a handwashing sink may not contaminate food, food contact surfaces, clean equipment or utensils. A washable baffle or barrier may be needed if the handwashing sink is located next to a food preparation or food contact surface and if the space between the handwashing sink and food, food preparation, food contact surfaces, and clean utensils does not provide adequate protection.

Similarly, the location of soap and paper towel dispensers at handwashing sinks must be reviewed during plan review so that their use does not contaminate food and food contact surfaces. In addition, the distance that employees would have to reach the faucet handles, soap and paper towels must be reviewed during plan review to assure that they will have proper access to the handwashing sinks and will not have to reach across dirty surfaces while washing their hands.

## **TOILET ROOMS**

Properly functioning toilet facilities must be accessible to employees at all times.

If required by federal, state, local or tribal laws and regulations, toilet facilities must be made available to the customers. If the public toilet facilities are used by employees, separate toilet facilities may not have to be installed for the employees. Toilet facilities must be made accessible in accordance with the Americans with Disabilities Act (ADA) of 1990.

The floors, walls, and ceiling in toilet rooms shall be smooth and easily cleanable. The walls around toilets, urinals, toilet paper dispensers, soap dispensers, and paper towel dispensers should be water resistant and durable for frequent cleaning.

The minimum requirements for toilet facilities shall include:

### **Toilet**

At least one toilet and not fewer than the number of toilets required by law shall be provided. If authorized by law, urinals may be substituted for toilets in men's toilet rooms.

### **Handwashing facility**

Each handwashing sink shall be provided with hot and cold water tempered by means of a mixing valve or a combination faucet to provide water at a temperature of at least 100°F. If used, self-closing, slow-closing or metering faucets shall be designed to provide a flow of water for at least 15 seconds without the need to reactivate the faucet.

### **Handwashing cleanser**

Each handwashing sink or group of two adjacent handwashing sinks shall be provided with hand cleaning liquid, powder or bar soap. A dispenser shall be provided for handwashing cleanser provided in liquid or powder form.

### **Hand drying facility**

Each handwashing sink or group of adjacent handwashing sinks shall be provided with individual, disposable towels; a continuous towel system that supplies the user with a clean towel; or heated-air hand drying device.

### **Toilet paper**

A supply of toilet paper shall be provided in a dispenser at each toilet.

### **Waste receptacle**

If disposable towels are used, a waste receptacle shall be located at each sink or group of sinks. At least one covered waste receptacle shall be provided in toilet rooms used by females.

**Ventilation**

Toilet rooms must be vented to the outside. Mechanical ventilation shall be installed in toilet rooms according to law. If allowed by law, openable screened windows may be used in lieu of mechanical ventilation devices.

**Toilet room doors**

Toilet room doors shall be tight-fitting and self-closing.

**Lighting**

At least 215 lux (20 foot candles) shall be provided in toilet rooms.

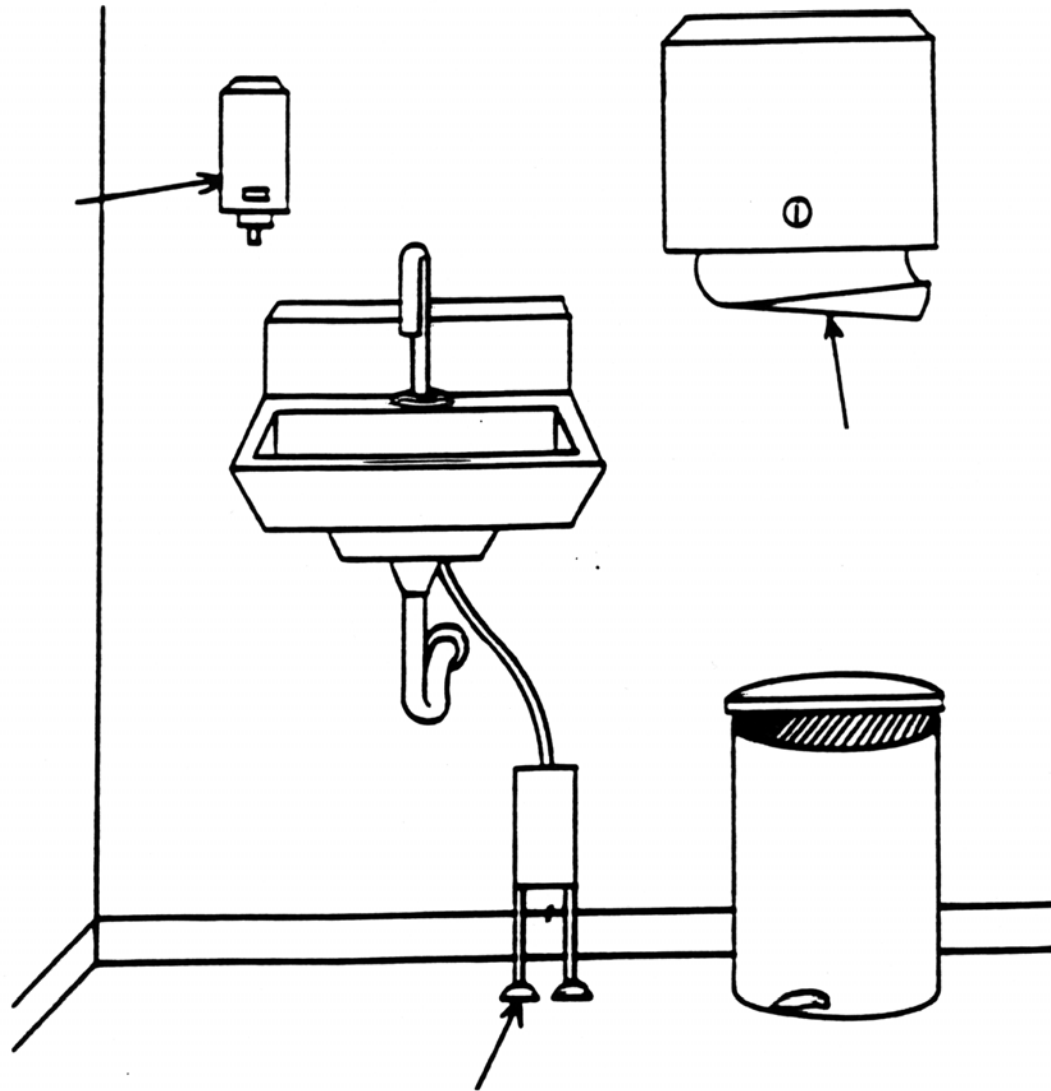

## SECTION 5 – WATER SUPPLY AND SEWAGE DISPOSAL

The primary concerns relative to the water supply and sewage disposal in a retail food establishment are to:

- 1) Ensure the facility is supplied with a safe and adequate water supply;
- 2) Verify that the water can remain safe while it is in the facility; and
- 3) Ensure the facility is disposing wastewater properly.

**Safe Source:** Start at the water source. Determine if the water is potable or non-potable. The availability of an approved public water supply must be verified. Any use of a non-public water source (well water) shall comply with local, state, and/or federal laws, and construction and testing standards.

What you need to review:

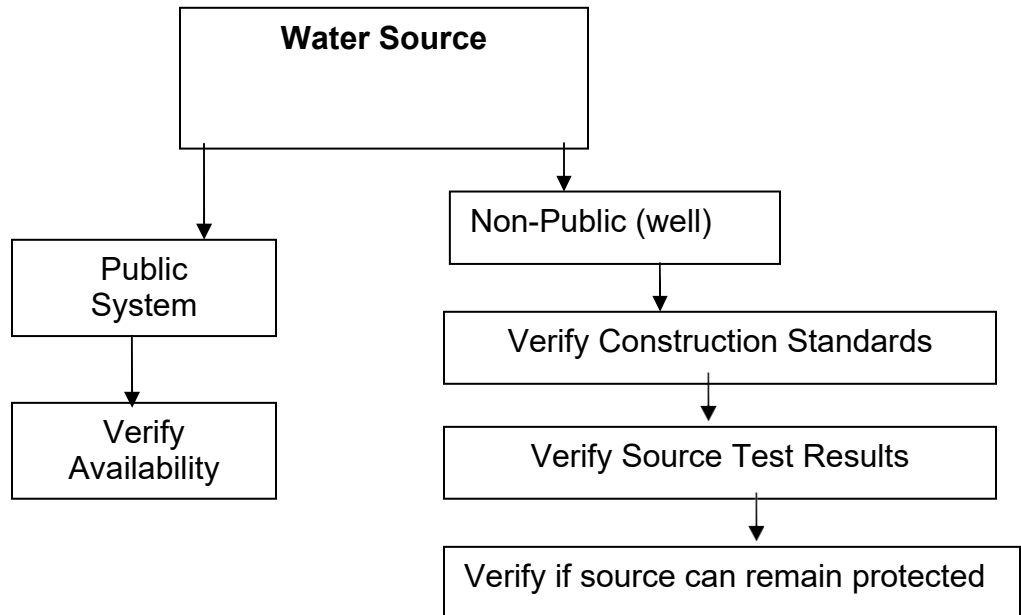

**Sufficient potable water:** Potable water shall be provided from a source constructed and operated according to law that meets the peak water demands of the food establishment.

**Hot Water Temperature:** The hot water supply shall be sufficient to satisfy peak hot water demands of the establishment. Hot water for handwashing and most food establishment uses shall be at least 100°F. Hot water for mechanical warewashing must be boosted up to 150°F-165°F for washing and 165°F-180°F for sanitizing or according to the manufacturer's data plate on the machine. The temperature of the wash solution for spray-type warewashers that use chemicals to sanitize may not be less than 120°F. The temperature of the wash solution for manual warewashing must be maintained to not



less than 110°F. The water temperature for manual hot water sanitization must be at least 171°F.

There are two primary methods used to determine hot water needs:

- Energy Methods
- Recovery Rate Model

Method 1: Energy Methods: (BTUs vs. KWs)

The energy method for determining hot water needs of food establishments is calculated by adding together all of the energy requirements for each fixture using hot water. For these calculations, it is generally assumed that the temperature of incoming water to the food establishment is 40° F unless specific data is provided and 1 gallon of water equals 8.33 lbs. It is necessary to calculate both the demand for hot water in gallons per hour (gph) and the temperature rise<sup>5</sup> needed for each piece of equipment. This information can then be converted to BTU's (for gas fired heaters) or KW (for electrical heaters). The required BTU or KW capacity of the water heater will then be determined by adding up the individual BTU or KW requirements for each piece of equipment.

Formula to calculate the BTU's needed for gas hot water heaters:

For gas heaters (in BTU's):  
 Required BTU = 
$$\frac{\text{Gallons per hour of water} \times \text{Temp. rise} \times 8.33}{.70 \text{ (operating efficiency)}}$$

Formula to calculate the KW's needed for electric hot water heaters:

For electrical heaters (in KW):  
 Required KW = 
$$\frac{\text{Gallons per hour of water} \times \text{Temp. rise} \times 8.33}{3412 \text{ (BTU's per KW)}}$$

The following examples illustrate the energy method of approximating the size of the hot water heater needed for the equipment specified:

<u>Equipment</u>	<u>Gallons Per Hour Demand from Chart or Spec. Sheet</u>	<u>Temperature Required</u>	<u>Temp. Rise</u>
3 Comp't sink	60	140°F	100°F
	<u>60 (gph) x 100 degree temp. rise x 8.33</u>		= 71,400 BTU's

<sup>5</sup> Temperature rise is the hot water temperature required minus the temperature of the water coming into the facility. For example, if the temperature of water entering a food establishment is 40° F and 100° F is needed at a handwashing sink, then the temperature rise would be 110° F - 40° F or 70° F.

.70 (operating efficiency)

OR

$$\frac{60 \text{ (gph)} \times 100 \text{ degree temp rise} \times 8.33}{3412 \text{ (BTU's per KW)}} = 14.65 \text{ KW}$$

---

<u>Equipment</u>	<u>Gallons Per Hour Demand from Chart or Spec. Sheet</u>	<u>Temperature Required</u>	<u>Temp. Rise</u>
Hand sink	5	110°F	70°F

$$\frac{5 \text{ (gph)} \times 70 \text{ degree temp rise} \times 8.33}{.70 \text{ (operating efficiency)}} = 4,165 \text{ BTU's}$$

OR

$$\frac{5 \text{ (gph)} \times 70 \text{ degree temp rise} \times 8.33}{3412 \text{ (BTU per KW)}} = 0.85 \text{ KW}$$

---

<u>Equipment</u>	<u>Gallons Per Hour Demand from Chart or Spec. Sheet</u>	<u>Temperature Required</u>	<u>Temp. Rise</u>
Chemical/ Mechanical warewasher	64	140°F	100°F

$$\frac{64 \text{ (gph)} \times 100 \text{ degree temp rise} \times 8.33}{.70 \text{ (operating efficiency)}} = 76,160 \text{ BTU's}$$

OR

$$\frac{64 \text{ (gph)} \times 100 \text{ degree temp rise} \times 8.33}{3412 \text{ (BTU per KW)}} = 15.62 \text{ KW}$$

---

Gallons Per Hour

<u>Equipment</u>	<u>Demand from Chart or Spec. Sheet</u>	<u>Temperature Required</u>	<u>Temp. Rise</u>
Hot water Sanitizing Mechanical warewasher	64	180°F	40°F
	$\frac{64 \text{ (gph)} \times 40 \text{ degree temp rise} \times 8.33}{.70 \text{ (operating efficiency)}}$		= 30,464 BTU's
	$\frac{64 \text{ (gph)} \times 40 \text{ degree temp rise} \times 8.33}{3412 \text{ (BTU per KW)}}$		= 6.2 KW

For mechanical warewashing, assume a hot water demand based on a primary rise in temperature to 140°F. A booster heater would then be needed to boost the required gallons per hour demand an additional 40°F to attain the required 180°F final rinse temperature. In this example, the total demand in BTU's or KW for the primary water heater would be:

3 Compartment sink	=	71,400 BTU or 14.65 KW
1 Hand sink	=	4,165 BTU or 0.85 KW
<u>1 Mechanical warewasher</u>	=	<u>76,160 BTU or 15.62 KW</u>
TOTAL DEMAND	=	151,725 BTU or 31.12 KW

In addition, a booster heater for the warewasher must be provided and sized to supply an additional 30,464 BTU or 6.2 KW.

All hot water generating equipment should conform to nationally recognized standards. The manufacturers' specification sheets (cut sheets) should be consulted for hot water supply requirements.

The above formula is one method of calculating the energy needed for water heaters. Other suitably developed calculations may be submitted for consideration.

## Method 2: Recovery Rate Model For Determining Hot Water Supply Requirements

Recovery rate is defined as the amount of hot water supplied by a water heater in one hour's time. Recovery rate is expressed in gallons per hour (GPH), and is determined by the water heater's input (BTW or kW) according to the following tables.

Hot water recovery is based on fixture requirements in accordance with the following guidelines:

Fixtures must be added together to determine hot water needs.

Prep sink compartments =	5 GPH each
Hand sinks =	5 GPH
Mop sinks =	10 GPH
Clothes washer =	15 GPH
Hose reel =	10 GPH
Pot sink = sink vat size inch <sup>3</sup> X # of compartments X .003255 inch <sup>3</sup>	
Example for pot sink:	
Sink vat size = (24X24X14) X 3 compartments X .003255 inch <sup>3</sup> = 79 GPH	
Dish machine =	70% of "final rise usage" found on manufacturer's spec sheet
Pre-rinse spray =	45 GPH

### Recovery Rates in Gallons per Hour - Electric Water Heaters

INPUT KW	Temperature Rise - Degrees Fahrenheit										
	40°	50°	60°	70°	80°	90°	100°	110°	120°	130°	140°
1	10	8	7	6	5	5	4	4	3	3	3
1.5	16	12	10	9	8	7	6	6	5	5	4
2	21	17	14	12	10	9	8	8	7	6	6
2.5	26	21	17	15	13	12	10	10	9	8	7
3	31	25	21	18	16	14	12	11	10	10	9
3.5	36	29	24	21	18	16	15	13	12	11	10
4	41	33	28	24	21	18	17	15	14	13	12
4.5	47	37	31	27	23	21	19	17	16	14	13
5	52	41	34	30	26	23	21	19	17	16	15
5.5	57	46	38	33	28	25	23	21	19	18	16
6	62	49	41	35	31	27	25	22	21	19	18
9	92	74	61	53	46	41	37	34	31	28	26
12	123	98	82	70	61	55	49	45	41	38	35
15	154	123	102	88	77	68	61	56	51	47	44
18	184	147	123	105	92	82	74	67	61	57	53
24	246	197	164	140	123	109	98	89	82	76	70
27	276	221	184	158	138	123	111	101	92	85	79
30	307	246	205	175	154	137	123	112	102	95	88
36	369	295	246	211	184	164	147	134	123	113	105
45	461	369	307	263	230	205	184	168	154	142	132
54	553	442	369	316	276	246	221	201	184	170	158

### Recovery Rates in Gallons per Hour - Gas Water Heaters

INPUT BTU	Temperature Rise - Degrees Fahrenheit										
	40°	50°	60°	70°	80°	90°	100°	110°	120°	130°	140°
20,000	45	36	30	26	23	20	18	17	15	14	13
26,000	59	47	39	34	30	26	24	21	20	18	17
28,000	64	51	42	36	32	28	25	23	21	20	18
30,000	68	55	45	39	34	30	27	25	23	21	19
32,000	73	58	48	42	36	32	29	26	24	22	21
34,500	78	63	52	45	39	35	31	29	26	24	22
36,000	82	65	55	47	41	36	33	30	27	25	23
37,000	84	67	56	48	42	37	34	31	28	26	24
40,000	91	73	61	52	45	40	36	33	30	28	26
50,000	114	91	76	65	57	51	45	41	38	35	32
57,000	130	104	86	74	65	58	52	47	43	40	37
60,000	136	109	91	78	68	61	55	50	45	42	39
69,000	157	125	105	90	78	70	63	57	52	48	45
75,000	170	136	114	97	85	76	68	62	57	52	49
98,000	223	178	148	127	111	99	89	81	74	69	64
100,000	227	182	152	130	114	101	91	83	76	70	65
114,000	259	207	173	148	130	115	104	94	86	80	74
156,000	355	284	236	203	177	158	142	129	118	109	101
160,000	364	291	242	208	182	162	145	132	121	112	104
180,000	409	327	273	234	205	182	164	149	136	126	117
199,900	454	363	303	260	227	202	182	165	151	140	130
250,000	568	455	379	325	284	253	227	207	189	175	162
270,000	614	491	409	351	307	273	245	223	205	189	175
300,000	682	545	455	390	341	303	273	248	227	210	195
360,000	818	655	545	468	409	364	327	298	273	252	234
399,900	909	727	606	519	454	404	364	330	303	280	260
500,000	1136	909	758	649	568	505	455	413	379	350	325

Based on 75% thermal efficiency.

SAMPLE CALCULATION

Three comp. sink -----	1	x	24x24x14	=	79
Two comp. Prep sink ----	2	x	10 GPH	=	20
Hand sink -----	5	x	5 GPH	=	25
Pre-rinse -----	1	x	45 GPH	=	45
Dishmachine -----	1	x	Note #1	=	52
Mop sink -----	1	x	10 GPH	=	10
Cloth Washer -----	1	x	15 GPH	=	15
Hose reel -----	2	x	10 GPH	=	20
				<b>Total =</b>	<b>266 GPH</b>

**Note #1** - Dishmachine - Hobart AM-14 Final Rinse GPH = 74

Using Note #1 - 74 gal/hr Final Rinse x .70% = 51.8(= 52 GPH)

**OTHER CONSIDERATIONS**

Tankless water heaters shall be installed and used in accordance with the manufacturer's recommendations.

Hot water recirculation systems should be considered when the water heater is over 100 feet from the farthest fixture served.

The use of smaller separate water heaters may be used for remote fixtures.

## **PLUMBING AND CROSS CONNECTION CONTROL**

Plumbing shall be sized and installed according to applicable codes. There shall be no cross connections between the potable water supply and any non-potable system or a system of unknown quality. Where non-potable water systems are permitted for purposes such as air conditioning and fire protection, the non-potable water must not contact directly or indirectly: food, potable water or equipment that contacts food or utensils. The piping of any non-potable water system shall be durably identified so that it is readily distinguishable from piping that carries potable water.

### **DEFINITIONS**

Cross connection is defined as any direct or indirect (potential) connection between a potable water system and a non-potable source, liquid or otherwise, through which backflow can occur.

Backflow is defined as the flow of water or other liquids, mixtures, or substances into a potable water system from any source, other than the intended source. There are two types of backflow: backpressure and back-siphonage.

Backpressure is defined as pressure in down stream piping greater than supply pressure causing a reversal of flow.

Back-siphonage is defined as the creation of backflow as a result of negative pressure. .

Direct connection is defined as a physical connection between a potable and non-potable system.

Indirect connection is defined as a potential connection between a potable and non-potable system.

An indirect connection may be one of two types, air gap or air break:

For a potable water supply, an air gap means the unobstructed, vertical air space that separates a potable system from a non-potable system. See figure 5-1.

For a drain, an air gap means the distance through the free atmosphere between the lowest opening from any drain pipe. See figure 5-4.

An air break is a waste line from a fixture that discharges used water or liquid waste to a drain. The connection does not provide an unobstructed vertical distance through the free atmosphere and is not solidly connected, but precludes the possibility of backflow to a potable water source into a sink or dishwasher/or fixture being drained. See figure #5-4.



There shall be no cross connections between the potable water supply and any non-potable water supply. The potable water system shall be installed to preclude the possibility of back flow and back siphonage. Devices shall be installed to protect against backflow and backsiphonage at all fixtures and equipment unless an air gap is provided.

**Types of Control: Backflow Control & Device Use**

As stated in the Food Code, a backflow or backsiphonage prevention device installed on a water supply system shall meet American Society of Sanitary Engineering (A.S.S.E.) standards for construction, installation, maintenance, inspection, and testing for that specific application and type of device.

Type of Control	Rules of Installation
Air Gap	The air gap must be the greater of the two - <b><u>A MINIMUM OF ONE INCH OR TWICE THE INSIDE DIAMETER OF THE PIPE.</u></b> For a supply line, this distance is measured from the supply pipe to the flood level rim (the point of over flow) of the receptacle or fixture. For a drain line, the distance is measured from the pipe from which the wastewater is being discharged.
Atmospheric Vacuum Breaker	1. Must be installed 6 inches higher than the outlet.
	2. Must be installed in the vertical position only
	3. Is not for continuous water pressure
	4. Must only be installed where it is not subject to backpressure
	5. Must be installed after the last shut off valve
Dual Check Valve with an Intermediate Atmospheric Vent	1. Can be installed horizontally or vertically.
	2. Must not be located in a pit or a location subject to standing water.
	3. Relief port or vent must not be plugged.
	4. Approved for low hazard, continuous pressure and backpressure or back-siphonge.
Dual Check Valve with an Intermediate Atmospheric Vent and 100 mesh screen	Must be used for water line to soda carbonation systems.
Pressure Type Vacuum Breaker	1. Must be installed at least 12 inches above the outlet.
	2. Must have a shut off valve on each side and two test cocks for testing.
	3. Must be located in an accessible area for testing and servicing.

	4. Not acceptable in a backpressure application
	5. Can be used for continuous pressure applications
Reduced Pressure Zone Device (RPZ)	1. Must be accessible for testing and service.
	2. Must be located above grade (not subject to flooding).
	3. Must be installed at least 12 inches from any wall and between 12 to 30 inches above the floor.
	4. Approved for high hazard, continuous pressure, backpressure or back-siphonage.
Hose Bibb Vacuum Breaker	Cannot be used for continuous pressure. Cannot have a shut off valve downstream of the device.

The following provides examples of equipment and their required backflow protection devices. See figure 5-2.

**Equipment**

**Required in Lieu of Air Gap**

- |  |   |
|--|---|
| 1. Boiler with chemicals added                   | Reduced pressure zone device  |
| 2. Boiler with no chemicals added                | Dual check valve with intermediate atmospheric vent                     |
| 3. Carbonators for beverage dispensers           | Dual Check Valve with intermediate atmospheric vent and 100 mesh screen |
| 4. Lawn sprinkler system with no chemicals added | Atmospheric or pressure vacuum breaker                                  |
| 5. Flush valve toilets                           | Atmospheric or pressure vacuum breaker                                  |

**Equipment**

**Required in Lieu of Air Gap**

- |  |                               |
|--|-------------------------------|
| 6. All hose bibbs inside & outside of establishments       | Hose bibb-type vacuum breaker |
| 7. Pre-flush hose with a nozzle head that may be submerged | Pressure vacuum breaker       |

8. Perforated pipe to woks	Atmospheric vacuum breaker
9. Submerged inlets	
a. Supply inlet to garbage grinder	Atmospheric vacuum breaker*
b. Supply inlet to dish table trough	" " "
c. Fill line for steam kettle	" " "
d. Supply line for mechanical warewashing machine	" " "
e. Garbage can washer	" " "
f. Water wash system for exhaust hood	Reduced pressure zone backflow preventer
g. Non-carbonated water line for soda guns	Dual check valve with intermediate atmospheric vent

### **Sewage Disposal**

All sewage including liquid waste shall be disposed into a public sewage system or an individual sewage disposal system constructed and operated according to law. Where individual sewage disposal systems are utilized, the location shall be noted on the plans and certification of compliance with state and local regulations shall be provided.

### **Drains**

A connection to a sewer line may be direct or indirect. A direct connection may not exist between the sewerage system and any drains originating from equipment in which food, portable equipment, or utensils are placed, except if otherwise required by law. When a warewashing machine is located within 5 feet of a trapped floor drain, the dishwasher waste outlet may be connected directly on the inlet side of a properly vented floor drain trap. See figure #5-3.

### **Grease Traps/Interceptors**

A grease trap/interceptor is a chamber designed for wastewater to pass through and allow any grease to float to the top for retention as the remainder of the wastewater passes through. If used, a grease trap shall be located to be easily accessible for cleaning. Food solids entering the grease trap/interceptor should be minimized.

It is recommended that waste water from fixtures or drains which would allow fats, oils, and grease to be discharged be directed to a grease trap/interceptor.

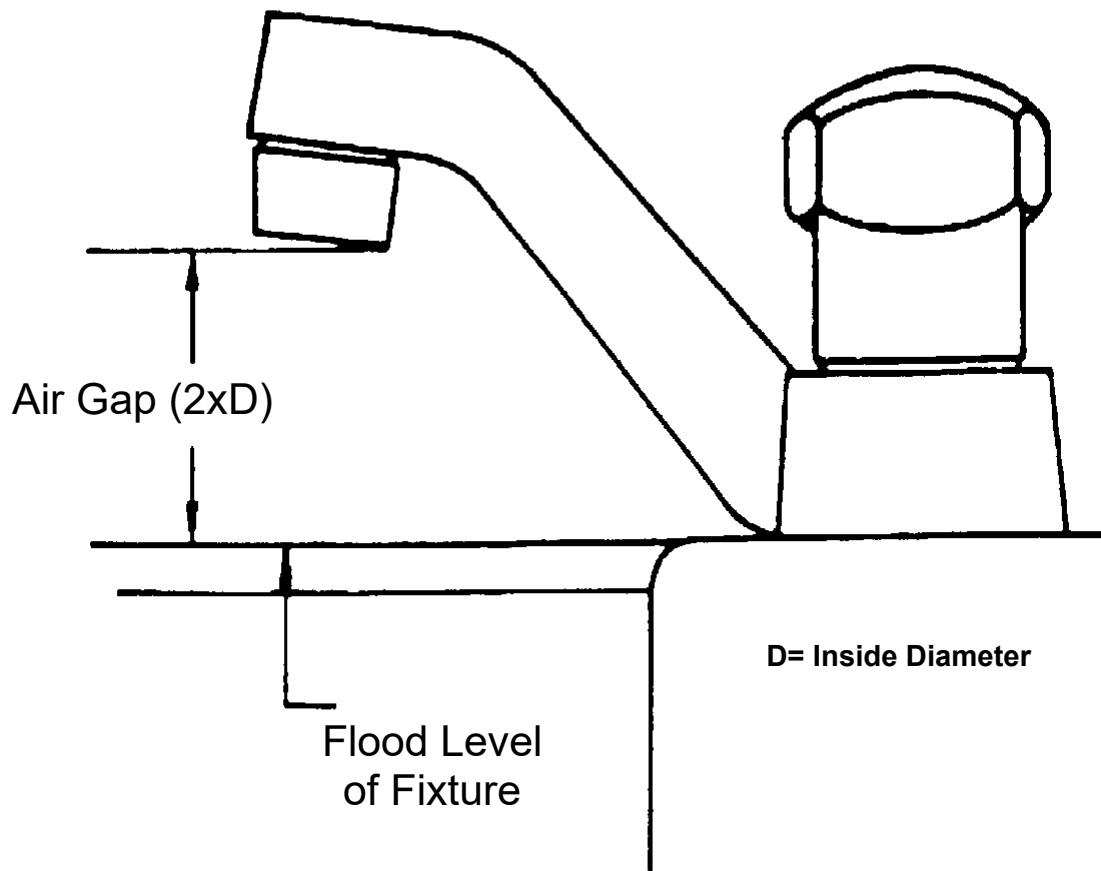

## Air Gap

Hose Bibb Vacuum Breaker

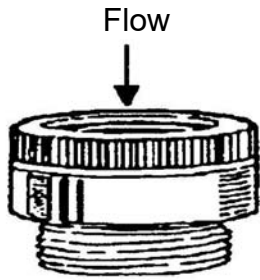

Atmospheric Vacuum Breaker

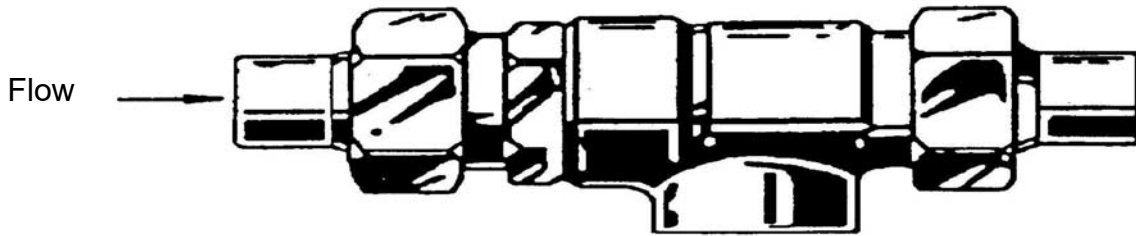
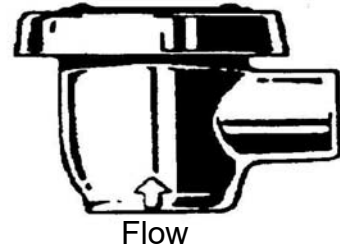

Backflow Preventer with Intermediate Vent

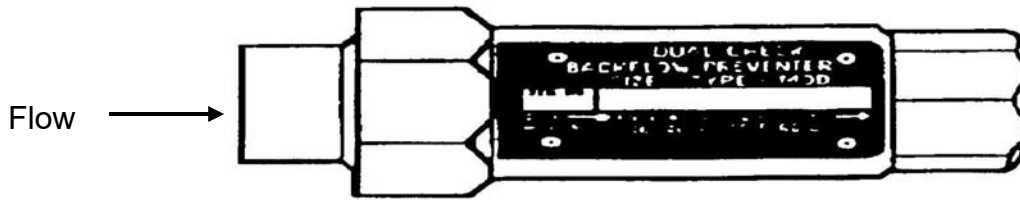

Dual Check Backflow Preventer

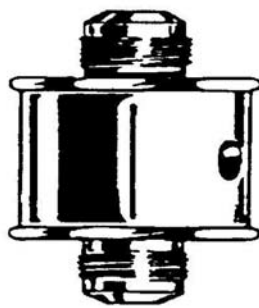

Carbonator Backflow Prevention

# Backflow Prevention Devices

Figure 5-2

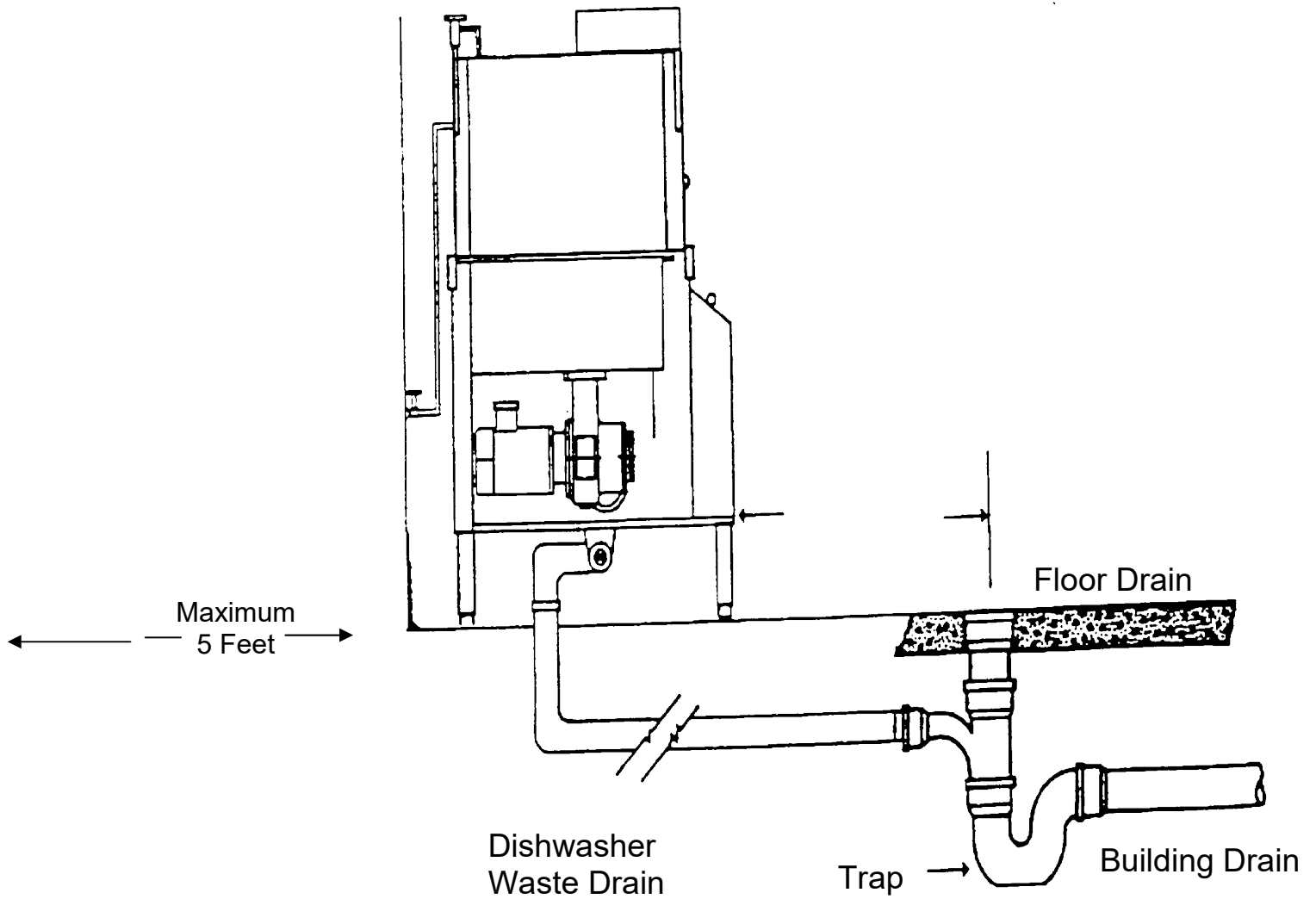

## Warewashing Machine With A Direct Waste Connection

Figure 5-3

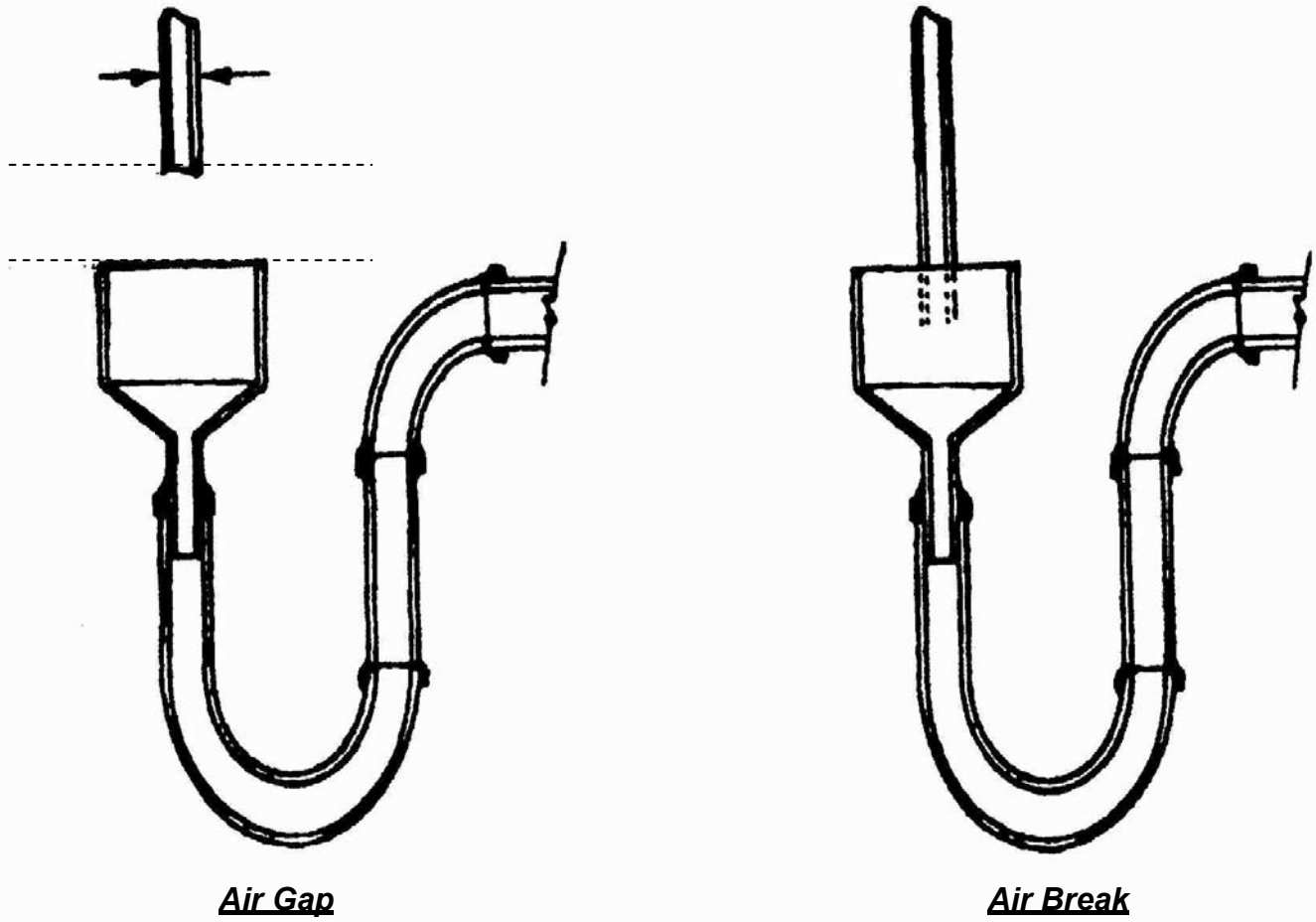

## Indirect Waste

Figure 5-4

## **SECTION 6- EQUIPMENT AND INSTALLATION**

All equipment in food establishments must comply with the design and construction standards contained in Chapter 4 of the FDA Food Code. Food equipment that is certified or classified for sanitation by an ANSI accredited program is deemed to comply with Parts 4-1 and 4-2 of the FDA Food Code.

Equipment including ice makers and ice storage equipment, shall not be located under exposed or unprotected sewer lines, open stairwells or other sources of contamination.

The following equipment installation recommendations will help ensure proper spacing and sealing allowing for adequate and easy cleaning:

### **FLOOR MOUNTED EQUIPMENT**

Equipment should be mounted on approved lockable casters or wheels to facilitate easy moving, cleaning, and flexibility of operation whenever possible. Moveable equipment requiring utility services such as gas or electrical connections should be provided with easily accessible quick-disconnects or the utility service lines should be flexible and of sufficient length to permit moving the equipment for cleaning. If a flexible utility line is used, a safety chain that is shorter than the utility line must be installed. Check with local fire safety and building codes to ensure that such installations are acceptable. See figures 6-1 and 6-3.

Floor-mounted equipment that is not mounted on wheels or casters with the above utility connections should be:

1. Permanently sealed to the floor around the entire perimeter of the equipment. The sealing compound should be pliable and non-shrinking. It should retain its elasticity and provide a water- and vermin-tight joint; or
2. Installed on a solid, smooth, non-absorbent masonry base. Masonry bases and curbs should have a minimum height of 2" and be covered at the junction of the platform and the floor with at least a 1/4" radius. The equipment should overhang the base by at least 1" but not more than 4". Spaces between the masonry base and the equipment must be sealed as above; or
3. Elevated on legs to provide at least a 6" clearance between the floor and equipment. The legs shall contain no hollow open ends. See figure 6-2.



4. For equipment not readily moveable by one person, spacing between and behind equipment must be sufficient to permit cleaning under and around the unit. Equipment shall be spaced to allow access for cleaning along the sides, behind and above. At least 6" of clear, unobstructed space under each piece of equipment must be provided or equipment must be sealed to the floor. See figure 6-4.
5. If equipment is against a wall and is not movable, the equipment must be joined to and/or sealed to the wall in a manner to prevent liquid waste, dust and debris from collecting between the wall and the equipment.
6. When equipment is joined together, or spreader plates are used between equipment, the resultant joint must be sealed to prevent liquid waste, dust and debris from collecting between the equipment.

Unobstructed and functional aisle and working spaces must be provided. A minimum width of 36" is required by fire and building codes.

All utility and service lines and openings through the floor and walls must be adequately sealed. Penetrations through walls and floors must be minimized. Exposed vertical and horizontal pipes and lines must be kept to a minimum. The installation of exposed horizontal utility lines and pipes on the floor is prohibited. Any insulation materials used on utility pipes or lines in the food preparation or dishwashing areas must be smooth, non-absorbent, and easy to clean. Electrical units which are installed in areas subject to splash from necessary cleaning operations or food preparation should be water-tight and washable.

#### COUNTER-MOUNTED EQUIPMENT

Counter-mounted equipment is defined as equipment that is not portable and is designed to be mounted off the floor on a table, counter, or shelf. All counter-mounted equipment shall be:

- A. Sealed to the table or counter; or
- B. Elevated on approved legs to provide at least a 4" clearance between the table or counter and the equipment to facilitate cleaning.

#### OTHER

Equipment that is open underneath, such as drain boards, dish tables, and other tables that are not moveable should be spaced to allow for ease of cleaning or should be sealed to the wall.

Non-food contact surfaces of equipment that are exposed to splash, spillage, or other food soiling or that require frequent cleaning shall be constructed of corrosion-resistant, non-absorbent, and smooth material.

Legs of all equipment should not have hollow, open ends.

If running water dipper wells are installed, methods for filling and draining the units must be identified.

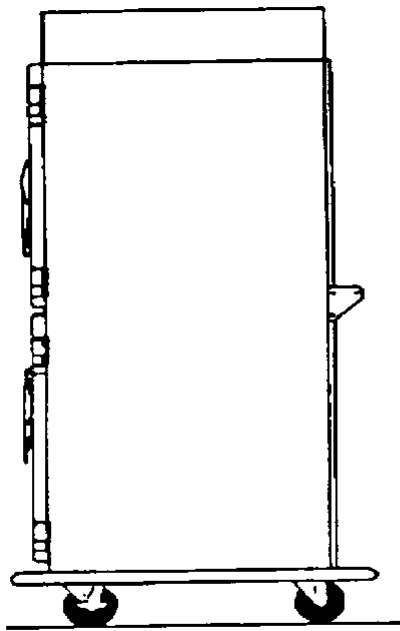

**Holding Cabinet**

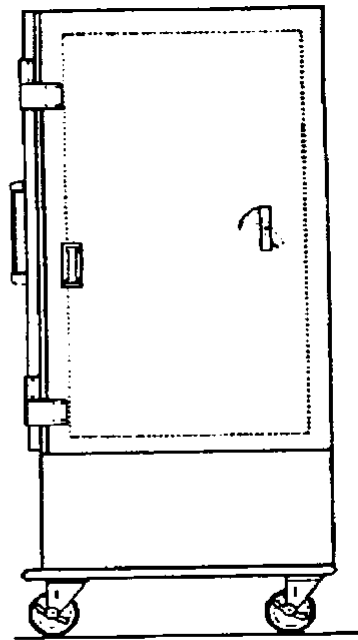

**Reach-in Refrigerator**

## **Kitchen Equipment Mounted On Castors**

**Figure 6-1**

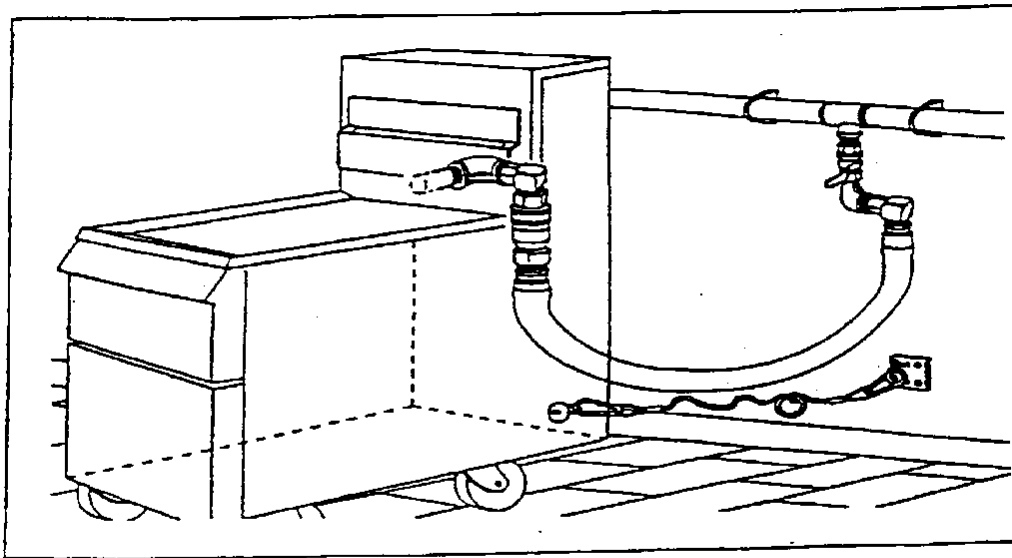
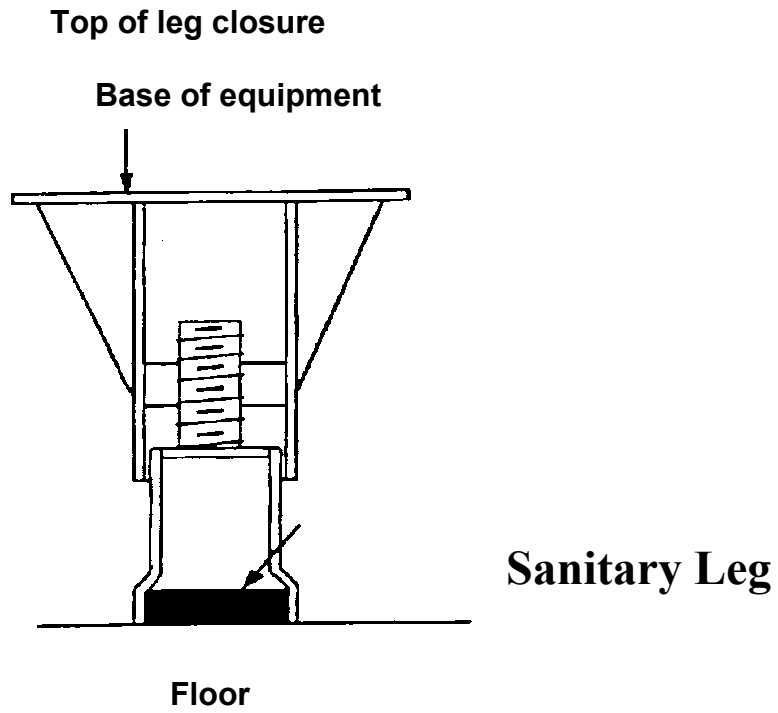

## Flexible Gas Connection With Safety Chain

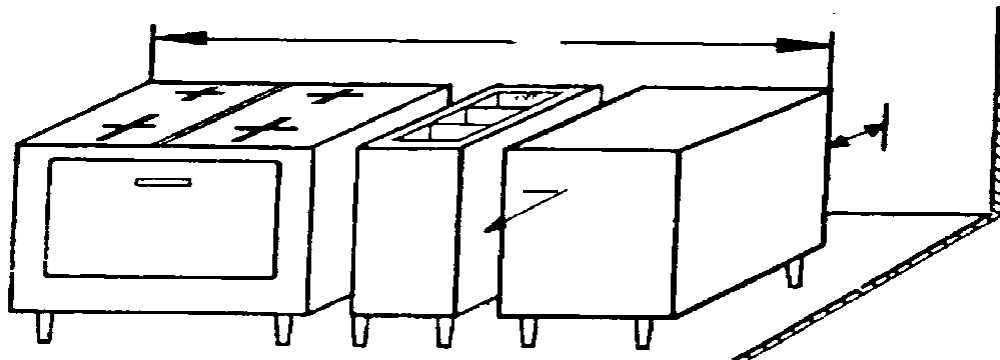
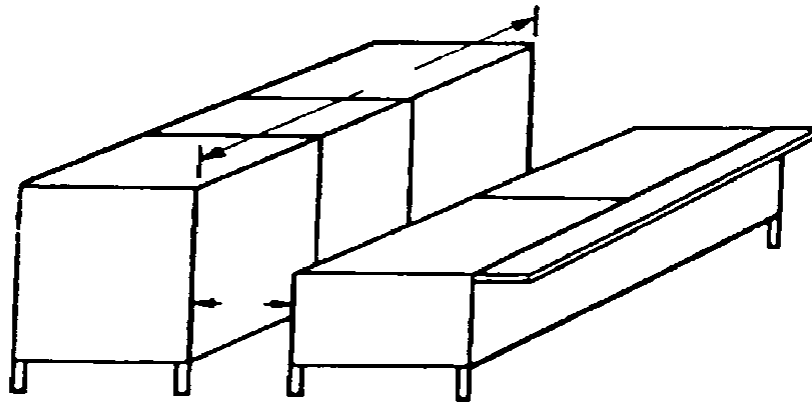

Recommended Equipment Spacing  
 Provided Access is Available From Both Ends:

<u>Equipment Length (A)</u>	<u>Space From Walls and Adjacent Equipment (B)</u>
4' or less	6"
4' - 8'	12"
8' or more	18"

## Equipment Spacing

## **PART 7 - DRY STORAGE**

The dry storage space needed depends on the menu, number of meals served between deliveries, frequency of deliveries, and the amount and type of single-service items to be stored. The location of dry storage should be adjacent to the food preparation area and convenient to receiving. Adequate ventilation should be provided. Food should not be stored under exposed sewer lines. Similarly, a cabinet that is used for the storage of food, shall not be located under exposed or unprotected sewer lines, open stairwells or other sources of contamination.

Shelving, dollies, racks, pallets and skids shall be corrosion-resistant, non-absorbent and smooth. The highest shelf for practical use should be 7 feet. The lowest one should be at least 6 inches from the floor. Clearance between shelves should be at least 15 inches. Sufficient moveable racks, skids and dollies should be provided to store all bulk containers. Shelving, dollies, racks, pallets and skids should be spaced away from walls to allow for cleaning and pest monitoring/inspection.

Approved food containers with tight-fitting covers and dollies should be used for storing bulk foods such as flour, cornmeal, sugar, dried beans, rice and similar food.

### **DRY STORAGE CALCULATION EXAMPLES:**

These formulas can be used to estimate dry storage space :

#### **Formula # 1 - Linear feet of storage shelving =**

$$\frac{\text{Volume per meal x number of meals between deliveries}}{D \times H \times C}$$

Volume per meal = 0.1 cubic feet

D = Depth of the shelves in feet

H = Distance between shelves in feet

C = 0.8 or 80% effective capacity of shelf height

For example, assume 400 meals per day and a 10 day storage between deliveries = 4000 meals between deliveries, shelf depth of 18 inches (1.5 ft.), clearance of 18 inches (1.5 ft.) between shelves and 80% effective capacity of shelf height:

Linear feet of storage shelving =

$$\frac{0.1 \text{ cu. ft} \times 4000 \text{ meals}}{1.5 \text{ ft.} \times 1.5 \text{ ft.} \times 0.8} = 222 \text{ Linear feet}$$

**Formula # 2 –Square feet of storage area =**

$$\frac{\text{Volume per meal} \times \text{number of meals between deliveries}}{\text{Average height (ft.)} \times \text{fraction of usable storeroom floor area}}$$

Volume per meal = 0.1 cu. ft

Usable storage height = 5 to 7 feet (total height of the ceiling minus the distance of shelving from the floor and ceiling)

Fraction of useable storeroom floor area=.4 to .6 (total floor area minus door openings, aisle space, distance of shelving from walls)

For example, assume 400 meals per day and a 10 day storage between deliveries = 4000 meals between deliveries, 5 feet useful storage height, and .5 of usable floor area.

$$\text{Storage Area} = \frac{0.1 \text{ cu.ft.} \times 4000 \text{ meals}}{5 \text{ ft.} \times .5} = 160 \text{ square feet}$$

<b>ESTIMATED LINEAR FEET OF STORAGE SHELVING NEEDED</b>				<b>ESTIMATED SQUARE FEET OF STORAGE AREA NEEDED</b>			
<b>(Formula #1)</b>				<b>(Formula #2)</b>			
Based on 0.1 cu. ft. per meal				Based on 0.1 cu. ft. per meal			
Meals Served Between Deliveries	1 ft. deep x 1ft. high shelves (D x H = 1)	1.5 ft. deep x 1.5 ft. high shelves (D x H = 2.25)	2 ft. deep x 1.5 ft. high shelves (D x H = 3)	Meals Served Between Deliveries	Height = 5 ft. Floor Area = .5	Height = 6 ft. Floor Area = .6	Height = 6 ft. Floor Area = .6
200	25	11	1	200	8	7	6
300	37.5	17	12.5	300	12	10	8
400	50	22	17	400	16	13	11
500	62.5	28	21	500	20	17	14
600	75	33	25	600	24	20	17
800	100	44	33	800	32	27	22
1000	125	55	42	1000	40	33	28
1500	187.5	83	62.5	1500	60	50	42
2000	250	111	83	2000	80	67	56
2500	312.5	139	104	2500	100	83	69
3000	375	167	125	3000	120	100	83
4000	500	222	167	4000	160	133	111
5000	625	278	208	5000	200	167	139

## **SECTION 8 - WAREWASHING FACILITIES**

The minimum requirement for warewashing in a food establishment is a 3-compartment sink. A mechanical warewashing machine may be installed in addition to the 3-compartment sink.

### **MANUAL WAREWASHING**

For manual warewashing, a stainless steel sink with no fewer than 3 compartments must be provided. The sink compartments shall be large enough to completely immerse the largest pot, pan or piece of equipment to be used in the establishment that will not be cleaned in place. Each compartment shall be supplied with adequate hot and cold potable running water. The temperature of the wash solution in manual warewashing equipment shall be maintained at not less than 110°F or the temperature specified on the cleaning agent manufacturer's label instructions. Drainboards, utensil racks or tables large enough to accommodate clean and soiled utensils shall be provided. The drainboards shall be self draining. A two-compartment sink may be allowed by the Regulatory Authority under certain conditions.

Adequate facilities for pre-flushing or pre-scrapping equipment and utensils must be provided.

If hot water is used to sanitize equipment and utensils, the means for heating the water to 171° F in the 3<sup>rd</sup> compartment must be identified. The racks for the immersion of equipment and utensil must be specified.

### **MECHANICAL WAREWASHING (see Figure #8)**

Warewashing machines shall be installed in accordance with the manufacturer's recommendations and applicable code requirements.

Adequate facilities shall be provided to air dry washed equipment and utensils. Drainboards, utensil racks or tables must be large enough to allow proper and sufficient air drying of equipment and utensils. Storage facilities shall be provided to store cleaned and sanitized utensils and equipment at least 6" above the floor; protected from splash, dust, overhead plumbing or other contamination. The plan must specify the location and facilities used for storing all utensils and equipment.

If used, the hot water booster for warewashing machines must be identified during plan review.

If the detergent dispenser or drying agent dispenser is not equipped with an integral backflow prevention device, the injection point of the chemicals shall be below the vacuum breaker on the warewashing machine.



## **SECTION 9 - FINISHES**

The finishes of the floors, walls, and ceilings in food establishments shall be smooth, durable, easily cleanable and be non-absorbent in areas exposed to moisture. Floor wall junctures shall be coved.

The chart below lists the types of floor, wall, and ceiling finishes that are acceptable in food establishments in the areas listed.

Room/Area	Floors	Walls	Ceilings
Cooking Areas  (Areas exposed to high heat)	Quarry tile Poured Epoxy Commercial Grade Vinyl Composition Tile (VCT) Commercial Grade Sheet Linoleum with Chemically Welded Seams	Stainless Steel Ceramic Tile Aluminum	Stainless Steel Smooth, Non-Acoustical Plastic Coated or Metal-Clad Fiberboard Dry-wall sealed with an Epoxy Finish Plastic Laminate Glazed Surfaces
Food Preparation  (No or low heat exposure)	Quarry tile Poured Epoxy Commercial Grade Vinyl Composition Tile (VCT) Commercial Grade Sheet Linoleum with Chemically Welded Seams	Stainless Steel Ceramic Tile Fiberglass Reinforced Polyester Panels (FRP) Concrete Block Filled with Epoxy Paint or Glaze	Smooth, Plastic Coated or Metal-Clad Fiberboard Dry-wall sealed with an Epoxy Finish Plastic Laminate Glazed Surfaces
Walk-in Refrigerators and Freezers	Insulated Metal Flooring Provided by the Manufacturer of the Walk-In Quarry tile Poured Epoxy	Insulated Wall Panels Provided by the Manufacturer of the Walk-In Stainless Steel Aluminum Fiberglass Reinforced Polyester Panels (FRP)	Insulated Ceiling Panels Provided by the Manufacturer of the Walk-In Stainless Steel Aluminum Fiberglass Reinforced Polyester Panels (FRP)
Warewashing Areas	Quarry tile Poured Epoxy Commercial Grade Vinyl Composition Tile (VCT) Commercial Grade Sheet Linoleum with Chemically Welded Seams	Stainless Steel Ceramic Tile Fiberglass Reinforced Polyester Panels (FRP) Concrete Block Filled with Epoxy Paint or a Glazed	Smooth, Non-Acoustical Plastic Coated or Metal-Clad Fiberboard Dry-wall sealed with an Epoxy Finish Plastic Laminate

		Surface	Glazed Surfaces
Food Storage	Quarry tile Poured Epoxy Commercial Grade Vinyl Composition Tile (VCT) Commercial Grade Sheet Linoleum with Chemically Welded Seams Smooth, Sealed Concrete	Stainless Steel Ceramic Tile Fiberglass Reinforced Polyester Panels (FRP) Concrete Block Filled with Epoxy Paint or a Glazed Surface Epoxy Sealed Dry-Wall	Plastic Coated or Metal-Clad Fiberboard Dry-wall sealed with an Epoxy Finish Plastic Laminate Glazed Surfaces
Other Storage	Quarry tile Poured Epoxy Commercial Grade Vinyl Composition Tile (VCT) Commercial Grade Sheet Linoleum with Chemically Welded Seams Smooth, Sealed Concrete	Stainless Steel Ceramic Tile Fiberglass Reinforced Polyester Panels (FRP) Concrete Block Filled with Epoxy Paint or a Glazed Surface Dry-wall sealed with an Epoxy Finish	Plastic Coated or Metal-Clad Fiberboard Dry-wall sealed with an Epoxy Finish Plastic Laminate Glazed Surfaces
Bar (Food Worker Side of Bar)	Quarry tile Poured Epoxy Commercial Grade Vinyl Composition Tile (VCT) Commercial Grade Sheet Linoleum with Chemically Welded Seams	Stainless Steel Ceramic Tile Fiberglass Reinforced Polyester Panels (FRP) Plastic Laminate Concrete Block Filled with Epoxy Paint or a Glazed Surface	Plastic Coated or Metal-Clad Fiberboard Dry-wall sealed with an Epoxy Finish Plastic Laminate Glazed Surfaces
Toilet Rooms	Quarry tile Poured Epoxy Commercial Grade Vinyl Composition Tile (VCT)	Stainless Steel Ceramic Tile Fiberglass Reinforced Polyester Panels (FRP)	Plastic Coated or Metal-Clad Fiberboard Dry-wall sealed with an Epoxy Finish

	Commercial Grade Sheet Linoleum with Chemically Welded Seams	Concrete Block Filled with Epoxy Paint or a Glazed Surface	Plastic Laminate Glazed Surfaces
Dressing Rooms	Quarry tile Poured Epoxy Commercial Grade Vinyl Composition Tile (VCT) Commercial Grade Sheet Linoleum with Chemically Welded Seams Smooth, Sealed Concrete	Stainless Steel Ceramic Tile Fiberglass Reinforced Polyester Panels (FRP) Concrete Block Filled with Epoxy Paint or a Glazed Surface Epoxy Sealed Dry-Wall	Plastic Coated or Metal-Clad Fiberboard Dry-wall sealed with an Epoxy Finish Plastic Laminate Glazed Surfaces
Garbage and Refuse (Interior Locations)	Quarry tile Poured Epoxy Commercial Grade Vinyl Composition Tile (VCT) Commercial Grade Sheet Linoleum with Chemically Welded Seams Commercially Manufactured Insulated Floor Panels	Stainless Steel Ceramic Tile Fiberglass Reinforced Polyester Panels (FRP) Concrete Block Filled with Epoxy Paint or a Glazed Surface Commercially Manufactured Insulated Wall Panels	Stainless Steel Plastic Coated or Metal-Clad Fiberboard Dry-wall sealed with an Epoxy Finish Plastic Laminate Glazed Surfaces Commercially Manufactured Insulated Ceiling Panels
Mop Service Areas	Quarry tile Poured Epoxy Commercial Grade Vinyl Composition Tile (VCT) Commercial Grade Sheet Linoleum with Chemically Welded Seams	Stainless Steel Ceramic Tile Fiberglass Reinforced Polyester Panels (FRP) Concrete Block Filled with Epoxy Paint or a Glazed Surface	Plastic Coated or Metal-Clad Fiberboard Dry-wall sealed with an Epoxy Finish Plastic Laminate Glazed Surfaces

Additional Notes: Finishes must be installed in accordance with the manufacturer's recommendations. If a new finish or texture is proposed, a sample of the material may be requested by the Regulatory Authority prior to installation.

## **SECTION 10 – PEST CONTROL**

Preventive measures during design and construction of a food establishment are essential to eliminating and controlling pest problems.

Food establishments should be designed and constructed to restrict the entrance of pests.

Openings to the outside shall be effectively protected against the entrance of pests. Openings to the outside shall be protected by the installation of tight fitting, self-closing doors; closed windows; self-closing windows at drive-throughs; screening; controlled air currents; vestibules; or other means approved by the Regulatory Authority. Screen doors shall be self-closing and screens for windows, doors, skylights, transoms, intake air ducts, exhaust vents and other openings to the outside shall be tight fitting and free of breaks. Screening material shall not be less than sixteen mesh to the inch. Openings around pipes, conduit or wiring must be sealed.

Loading docks and delivery doors must be provided with effective air curtains or vestibules with self-closing doors to preclude the entrance of insects.

Insect control devices are effective tools in controlling flying insects that have entered a food establishment. Electrocuting units shall be designed to retain the insect within the device. Insect control devices may not be located over a food preparation area and should be installed in accordance with the manufacturer's recommendations.

The presence of pests shall be controlled throughout the premises. Openings between the floor and bottom of the doors to the outside shall be adequately flashed with rodent proof material/weather stripping to eliminate any opening.

## **SECTION 11 – LIGHTING**

The light intensity shall be at least 108 lux (10 foot candles) at a distance of 75 cm (30 inches) above the floor, in walk-in refrigeration units and dry food storage areas and rooms during periods of cleaning.

The light intensity shall be at least 215 lux (20 foot candles) at a surface where food is provided for consumer self-service such as buffets and salad bars or where fresh product or packaged foods are sold or offered for consumption; inside equipment such as reach-in and under-counter refrigerators; at a distance of 75 cm (30 inches) above the floor in areas used for handwashing, warewashing, and utensil storage, and in toilet rooms.

The light intensity shall be at least 540 lux (50 foot candles) at a surface where a food employee is working with food or working with utensils or equipment such as knives, slicers, grinders, or saws where employees safety is a factor.

Shielding such as plastic shields, plastic sleeves with end caps, shatterproof bulbs and/or other approved devices shall be provided for all artificial lighting fixtures located in areas where there is exposed food; clean equipment, utensils, and linens; or unwrapped single-service and single-use articles.

Heat lamps shall be protected against breakage by a shield surrounding and extending beyond the bulb, leaving only the face of the bulb exposed.

## **SECTION 12 – VENTILATION**

All rooms shall have sufficient ventilation to keep them free of excessive heat, steam, vapors, obnoxious odors, smoke and fumes. Ventilation systems shall be designed and installed according to law.

### **GENERAL PRINCIPLES OF EXHAUST**

The purpose of an exhaust hood is to provide a method of collecting, as nearly as possible, all of the grease produced from the cooking process while furnishing a means of removing heat, smoke and odors from the cooking area. A sufficient volume of air movement (capture velocity) must be provided to effectively draw grease particles and cooking vapors directly from the cooking surface to the grease extractors. This air flow removes cooking odors and keeps grease particles from settling onto nearby surfaces.

An effective capture velocity shall be sufficient to overcome opposing air currents, capture the grease and cooking vapors, and transport them to the grease extractors. When grease vapors cool and condense, an extractor removes grease particles by directed air flow, contraction, and expansion (drop out).

For heat and steam producing equipment, the hood or ventilation system controls humidity, heat and unwanted condensation.

### **COOKING EQUIPMENT**

Cooking ventilation hoods and devices shall be designed and installed to prevent grease or condensation from collecting on walls, ceilings, and fire suppression supply piping and from dripping into food or onto food contact surfaces.

Make up air intakes must be screened and filtered to prevent the entrance of dust, dirt, insects and other contaminating material. Where the introduction of makeup air will cause condensation, drafting or interfere with the exhaust or vapor capture efficiency of the hood, the makeup air must be tempered. Tempering of makeup air may be necessary in certain climates.

Exposed piping must be cleanable.

### **HOT WATER SANITIZING WAREWASHING MACHINES**

Exhaust ventilation may be necessary over hot water sanitizing warewashing machines to minimize moisture and steam.

### **FIRE PROTECTION**

Fire protection for equipment that produces grease-laden vapors is regulated by National Fire Protection Association Bulletin #96.

Other references are available for additional formulas and information. Such references

include:

North American Association of Food Equipment Manufactures. An Introduction to the Food Service Industry. First Edition 1995.

National Environmental Health Association. Manual of Recommended Practice for Ventilation in Food Service Establishments, by James D. Barnes. 1984.



## **SECTION 13 – OTHER**

### **Service Sink**

At least one service sink or one curbed cleaning facility equipped with a floor drain shall be provided and conveniently located for the cleaning of mops or similar wet floor cleaning tools and for the disposal of mop water and similar liquid waste.

There shall be a place to store mops and similar cleaning items where they can be air dried after use.

### **Poisonous or Toxic Materials**

Poisonous or toxic materials shall be stored so they cannot contaminate food, equipment, utensils, linens, and single-service and single-use articles.

These items can be separated by using spacing or partitioning. Poisonous or toxic materials cannot be located above food, equipment, utensils, linens, or single-service and single-use articles.

### **Clothes Washers and Dryers**

If a mechanical clothes washer and dryer are proposed, they must be located away from exposed food, clean equipment, utensils, and linens; and unwrapped single-service and single-use articles.

### **Dressing Rooms and Lockers**

Lockers must be provided to store employees' belongings and clothing. If lockers are not used, another type of area can be designated and identified on the plan for the storage of employees' belongings.

If employees will be changing their clothes or putting on uniforms in the establishment, a dressing room must be designated on the plans.

### **Storage and Disposal Facilities for Grease Waste, Refuse, Recyclables, and Returnables**

#### **Indoor Storage**

If grease waste, refuse, recyclables, and returnables are stored inside the establishment, the floors, walls, and ceilings of the storage area must be smooth, durable, easily cleanable, and nonabsorbent. The area must be rodent-proof and insect-proof and must have sufficient capacity to hold the items being stored before removal. If the food establishment is located in a warm weather climate, air conditioned or refrigerated storage rooms should be considered as a method that can be used to minimize odors and decomposition of the waste materials.

Storage rooms must be separated from food, equipment, utensils, linens, and single-service and single-use articles.

#### Outdoor Storage

The outdoor storage surface for the storage of grease waste, refuse, recyclables, and returnables shall be constructed of concrete, asphalt, or other nonabsorbent material. The surface shall be smooth and durable and sloped to drain. If an enclosure is used around the storage area, it must be constructed of durable and cleanable materials. The area must have sufficient capacity to hold the items being stored before removal.

## **FOOD CODE REFERENCE SHEET**

### **A. ADMINISTRATIVE CONSIDERATIONS**

#### Plan Submission and Approval

- 8-201.11 When Plans Are Required.
- 8-201.12 Contents of the Plans and Specifications.
- 8-201.13 When a HACCP Plan is Required.
- 8-201.14 Contents of a HACCP Plan.
- 8-203 Construction Inspection and Approval

### **B. PHYSICAL FACILITIES**

#### Materials for Construction and Repair

- 6-101.11 Surface Characteristics. (Indoor Areas)
- 6-102.11 Surface Characteristics. (Outdoor Areas)

#### Design, Construction, and Installation (Cleanability)

- 6-201.11 Floors, Walls, and Ceilings.
- 6-201.12 Floors, Walls, and Ceilings, Utility Lines.
- 6-201.13 Floor and Wall Junctures, Coved, and Enclosed or Sealed.
- 6-201.14 Floor Carpeting, Restrictions and Installation.
- 6-201.15 Floor Covering, Mats and Duckboards.
- 6-201.16 Wall and Ceiling Coverings and Coatings.
- 6-201.17 Walls and Ceilings, Attachments.
- 6-201.18 Walls and Ceilings, Studs, Joists and Rafters.

#### Design, Construction, and Installation (Functionality)

- 6-202.11 Light Bulbs, Protective Shielding.
- 6-202.12 Heating, Ventilating, Air Conditioning System Vents.
- 6-202.13 Insect Control Devices, Design and Installation.
- 6-202.14 Toilet Rooms, Enclosed.
- 6-202.15 Outer Openings, Protected.
- 6-202.16 Exterior Walls and Roofs, Protective Barrier.
- 6-202.17 Outdoor Food Vending Areas, Overhead Protection.
- 6-202.18 Outdoor Servicing Areas, Overhead Protection.
- 6-202.19 Outdoor Walking and Driving Surfaces, Graded to Drain.
- 6-202.110 Outdoor Refuse Areas, Curbed and Graded to Drain.
- 6-202.111 Private Homes and Living or Sleeping Quarters, Use Prohibition.
- 6-202.112 Living or Sleeping Quarters, Separation.

## Numbers and Capacities

- 6-301 Handwashing Facilities.
- 6-302 Toilets and Urinals.
- 6-303 Lighting.
- 6-304 Ventilation.
- 6-305 Dressing Areas and Lockers.
- 6-306 Service Sinks.

## Location and Placement

- Handwashing Facilities.
- Toilet Rooms.
- Employee Accommodations.
- Distressed Merchandise.
- Refuse, Recyclables, and Returnables.

## ***C. WATER, PLUMBING, AND WASTE***

### Water

- 5-101 Source.
- 5-102 Quality.
- 5-103 Quantity and Availability.
- 5-104 Distribution, Delivery, and Retention.

### Plumbing System

- 5-201 Materials.
- 5-202 Design, Construction, and Installation.
- 5-203 Numbers and Capacities.
- 5-204 Location and Placement.
- 5-205 Operation and Maintenance

### Mobile Water Tank and Mobile Food Establishment Water Tank

- 5-301 Materials.
- 5-302 Design and Construction.
- 5-303 Numbers and Capacities.
- 5-304 Operation and Maintenance

### Sewage, Other Liquid Waste, and Rainwater

- 5-401 Mobile Holding Tank.
- 5-402 Retention, Drainage, and Delivery.
- 5-403 Disposal Facility.

### Refuse, Recyclables, and Returnables

- 5-501 Facilities on the Premises.
- 5-502 Removal.
- 5-503 Facilities for Disposal and Recycling.

## ***D. EQUIPMENT, UTENSILS, AND LINENS***

### Applicable Parts of Food Code Chapter 4

- 4-1 Materials for Construction and Repair.
- 4-2 Design and Construction.
- 4-3 Numbers and Capacities.
- 4-4 Location and Installation.
- 4-5 Maintenance and Operation
- 4-6 Cleaning of Equipment and Utensils
- 4-7 Sanitization of Equipment and Utensils
- 4-8 Laundering
- 4-9 Protection of Clean Items

## OTHER REFERENCES

The following is a list of reference materials and resources that can be used when planning a food establishment or reviewing plans for a food establishment. These resources include additional formulas and explanations for the materials presented above.

- Baraban, Regina S. and Joseph F. Durocher, Successful Restaurant Design, New York , NY: Van Nostrand Reinhold.
- Barnes, James D., Manual of Recommended Practice for Ventilation in Food Service Establishments, National Environmental Health Association.
- Birchfield, John C., Design and Layout of Foodservice Facilities, New York, NY: Van Nostrand Reinhold, 1984.
- Food and Drug Administration, 2005 Food Code, National Technical Information Service, Springfield, VA.
- Kazarian, Edward A., Foodservice Facilities Planning, Third Edition, Copyright Van Nostrand-Reinhold, New York, 1989.
- NAFEM, National Association of Food Equipment Manufactures, Introduction to the Food Service Industry (Kitchen Design).
- North American Association of Food Equipment Manufactures, An Introduction to the Foodservice Industry, First Edition, 1996.
- Salvato, J. A., Environmental Engineering & Sanitation, Fourth Edition, Copyright John Wiley & Sons, Inc., United States and Canada, 1992.
- Scriveen, Carl and James Stevens, Food Equipment Facts, Troy, NY: Conceptual Design , 1980 or latest printing (or equal publication).
- Stipanuk, David M. and Roffman, Harold Hospitality Facilities Management and Design, American Hotel & Motel Association, Educational Institute, 1992.